

ISOMAG

The friendly magmeter

DATA SHEET

MV145



CE

ISOIL 
I N D U S T R I A



INDEX

TECHNICAL DATA	4
OVERALL DIMENSIONS	6
OVERALL DIMENSIONS	9
MV145 EXPLODED LAYOUT	12
CONVERTER ACCESS	14
BATTERY POWER SUPPLY	15
MAIN POWER SUPPLY	16
ELECTRICAL CONNECTIONS	17
FUNCTIONS MENU	18
DIGITAL INPUTS	19
DIGITAL OUTPUTS	19
AUXILIARY MODULE ANALOG INPUTS	20
4÷20 MA OUTPUTS	22
MODBUS (RS485)	23
AUXILIARY MODULE DIGITAL INPUTS/ OUTPUTS	24
FUNCTIONS MENU	25
MEASUREMENT SETTINGS	30
MAIN PAGES VISUALIZATION	31
USER INTERFACE	32
DATA LOGGER	33
ACCURACY	34
MI-001 OIML R49 CLASS1: MV145	35
MI-001 OIML R49 CLASS2: MV145	36
HOW TO ORDER	39

TECHNICAL DATA

OVERALL FEATURES	
Suitable For	<input type="checkbox"/> All the ISOMAG® sensors
Minimum conductivity	<input type="checkbox"/> 5 µS/cm
Altitude	<input type="checkbox"/> -200 m up to 4000 m
Ambient Temperature	<input type="checkbox"/> -20... +60°C / -4... +140 °F - Aluminium housing <input type="checkbox"/> -10... +50°C / -4... +104 °F - Reinforced Nylon
Humidity Range	<input type="checkbox"/> 0÷100%

STANDARD FEATURES	
Version	<input type="checkbox"/> Compact <input type="checkbox"/> Separate
Housing materials	<input type="checkbox"/> Painted Aluminium die casting Or Nylon reinforced with 15% of fiber glass
Protection Rate	<input type="checkbox"/> IP 67
Power Supply/Consumption	<input type="checkbox"/> Network/ Primary Lithium Batteries / Alkaline Batteries (50mW ... 4W)
Cable Gland	<input type="checkbox"/> N° 5 cable gland PG 11
Full scale value	<input type="checkbox"/> 0,4...10m/s
Dig. Input	<input type="checkbox"/> N°1 , programmable function (i.e. Totalizer reset)
Data Storage	<input type="checkbox"/> F-Ram
Galvanic Isolation	<input type="checkbox"/> All analog / digital inputs / outputs are galvanically isolated (500V)
Programming Plug In	<input type="checkbox"/> PC connection via USB (A / USB MINI B type cable must be used)
Bidirectional	<input type="checkbox"/> Yes
Diagnostic Funct.	<input type="checkbox"/> Yes
Empty Pipe Detect.	<input type="checkbox"/> Yes
CE Certification	<input type="checkbox"/> Yes

OPTIONAL FEATURES (CHECK HOW TO ORDER, AT LAST PAGE, FOR MORE DETAILS)	
Protection Rate	<input type="checkbox"/> IP 68 (Aluminium)
Conn. Sensor Cable	<input type="checkbox"/> CABLE C015-C016
LCD Display	<input type="checkbox"/> 128x64 pixel backlit graphic display (Main power version only), with 3 keys for programming
Outputs: Pulses/ Alarm	<input type="checkbox"/> N°2...4 DIGITAL OUTPUT, Max 50 Hz, 100mA, 30 V (AC/DC) <input type="checkbox"/> N°1...3 DIGITAL INPUT
Analog Output	<input type="checkbox"/> N ° 1 Analog Output 4 ... 20 mA
Data logger	<input type="checkbox"/> MicroSD Memory 4 GB : Data Logger + RTC (Real Time Clock) <input type="checkbox"/> MicroSD Memory 4 GB : Data Logger + RTC (Real Time Clock) + BIV (Built In Verificator) <input type="checkbox"/> MicroSD Memory 4 GB : Data Logger + RTC (Real Time Clock) + Meter Data (Real Time Converter & Sensor Data on SD Memory) <input type="checkbox"/> MicroSD Memory 4 GB : Data Logger + RTC (Real Time Clock) + BIV + Meter Data
Communication Gateway	<input type="checkbox"/> RS 485
Data Logger	<input type="checkbox"/> MicroSD Memory Card 4...32 GBytes
Protocols	<input type="checkbox"/> ModBus RTU (speed range setting bps: 4800 /9600 / 19200/ 22800/ 38400/ 57600)
MID Certifications	<input type="checkbox"/> MI-001 

ACCURACY	
Measurements tolerance	<input type="checkbox"/> Flow rate (volume) = $\pm 0,1\%$ v.l. <input type="checkbox"/> Out 4/20 mA = $\pm 0,2\%$ v.l. <input type="checkbox"/> Frequency Out = $\pm 0,2\%$ v.l.
Accuracy (Whole System Converter+Sensor)	<input type="checkbox"/> See table below

OVERALL DIMENSIONS

Without battery pack

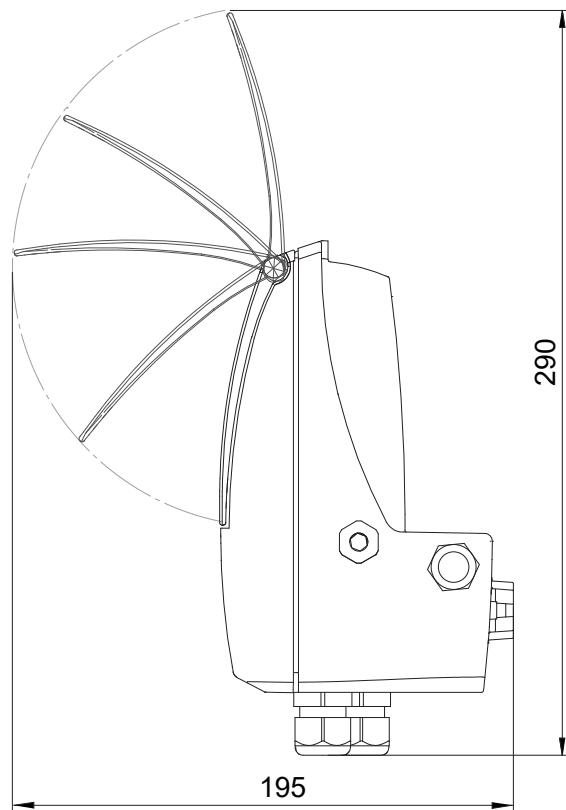
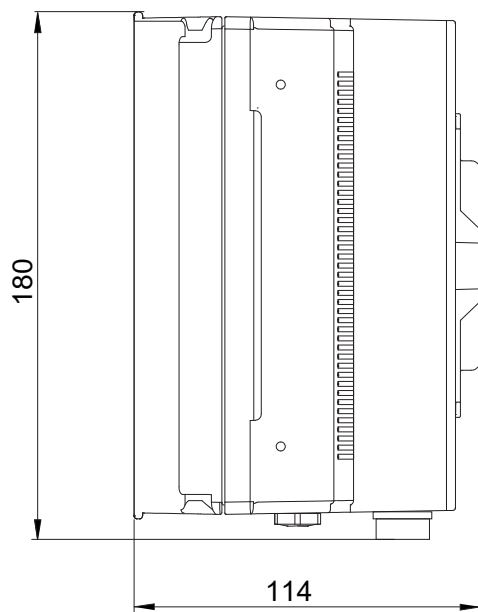
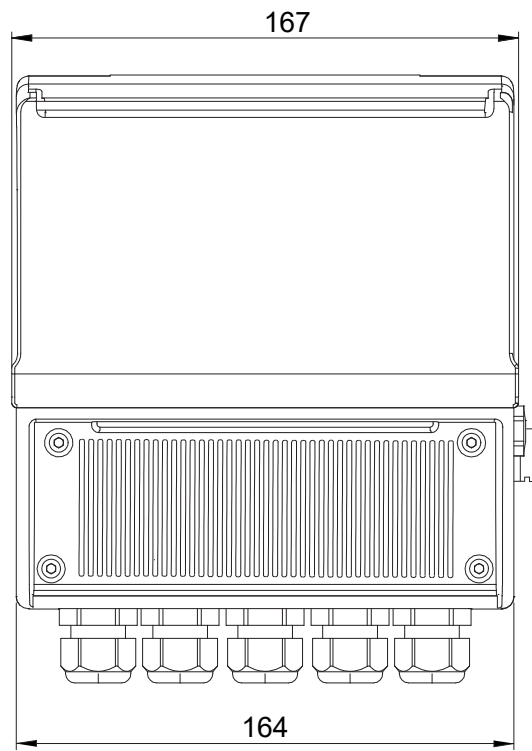
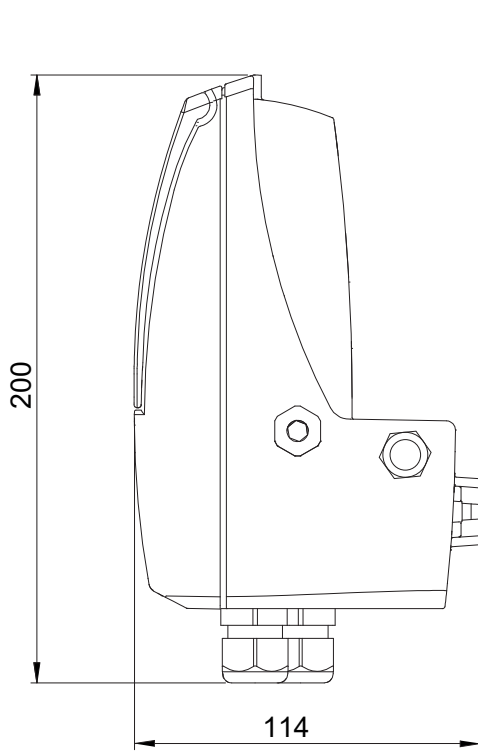

The manufacturer guarantees only English text available on our web site www.isoil.com

Orrizontal compact version

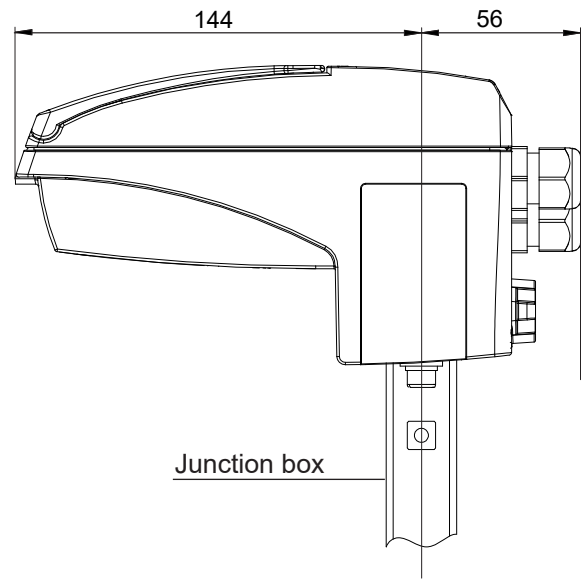
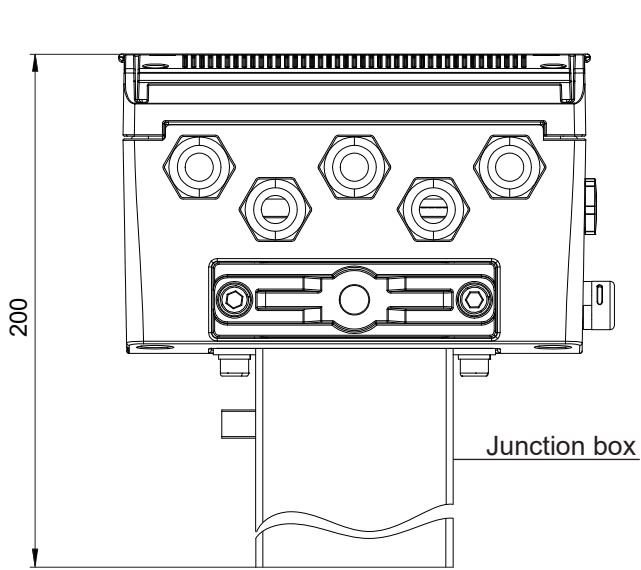

Vertical compact version

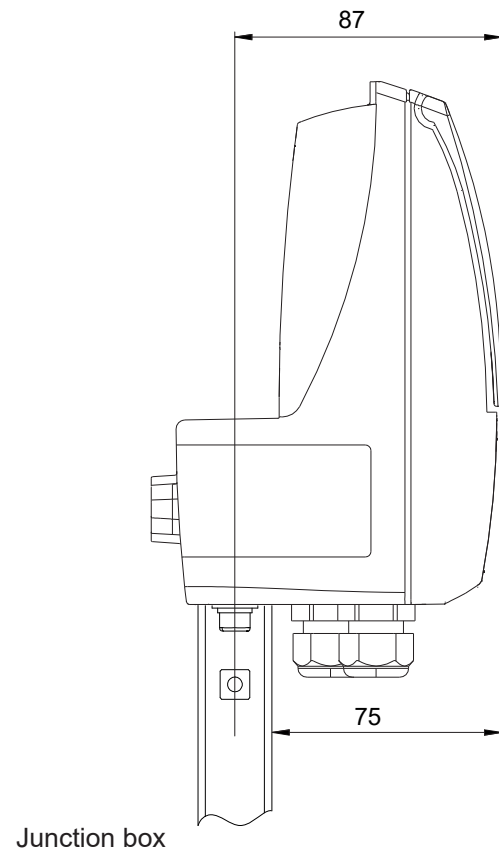
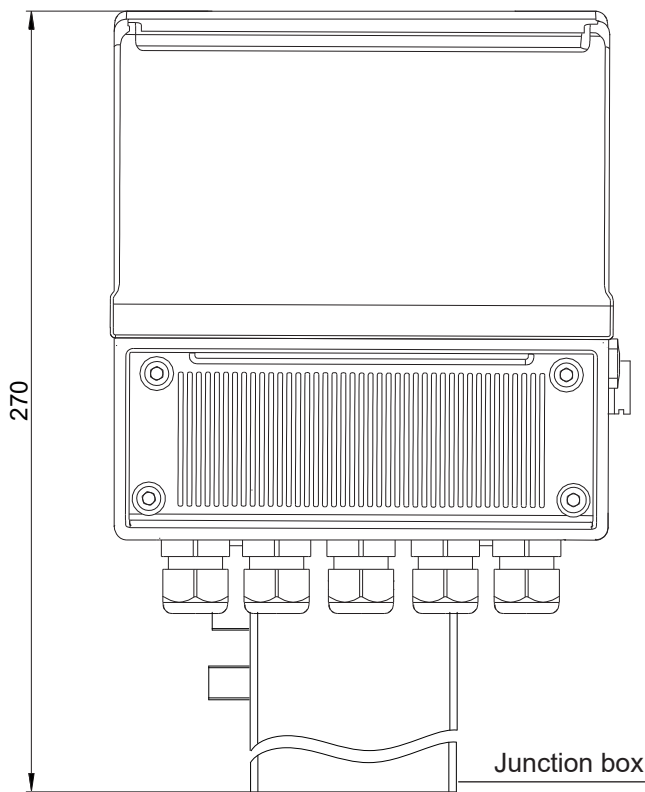

The manufacturer guarantees only English text available on our web site www.isoil.com

Separate (wall) version

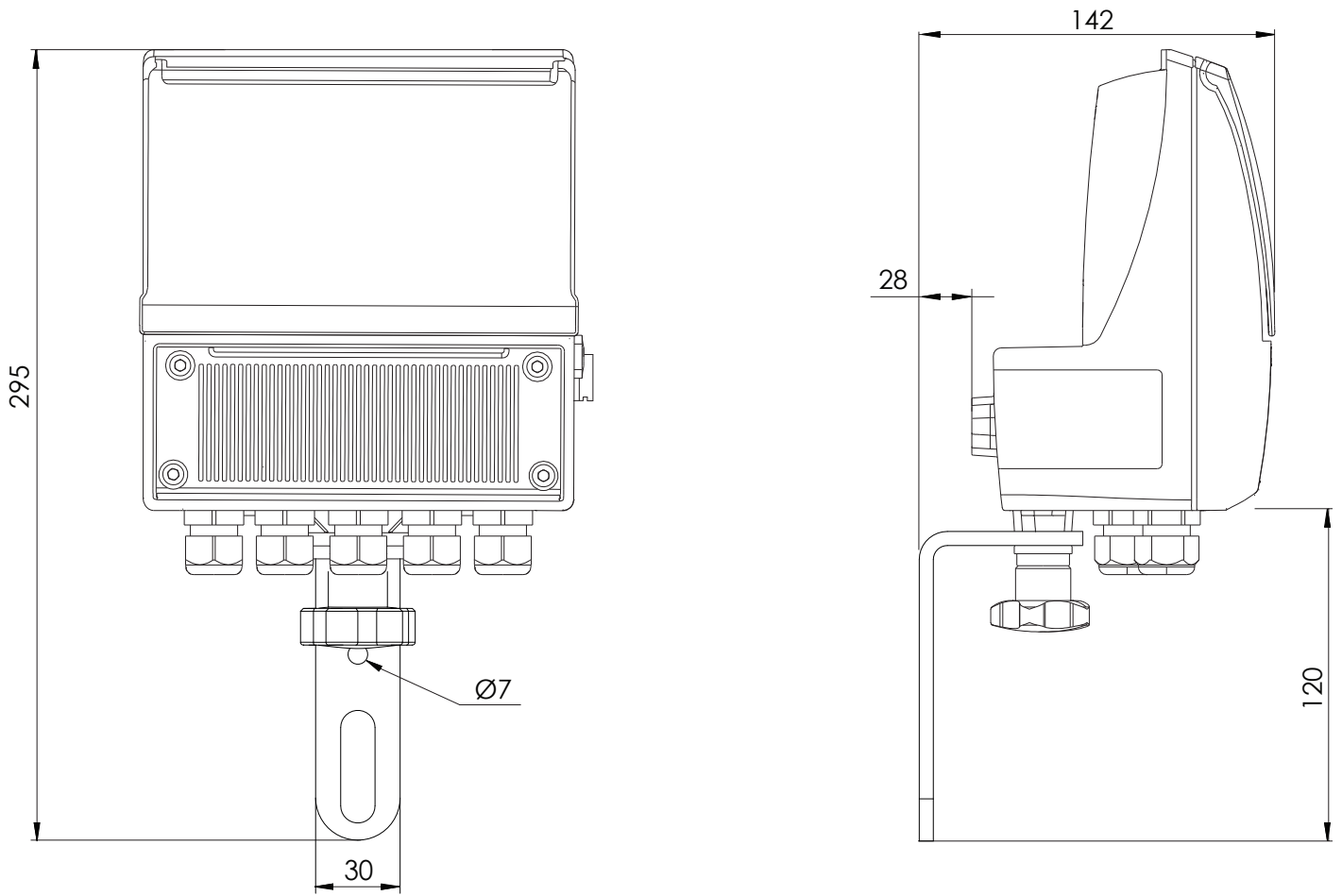

The manufacturer guarantees only English text available on our web site www.isoil.com

OVERALL DIMENSIONS

With battery pack

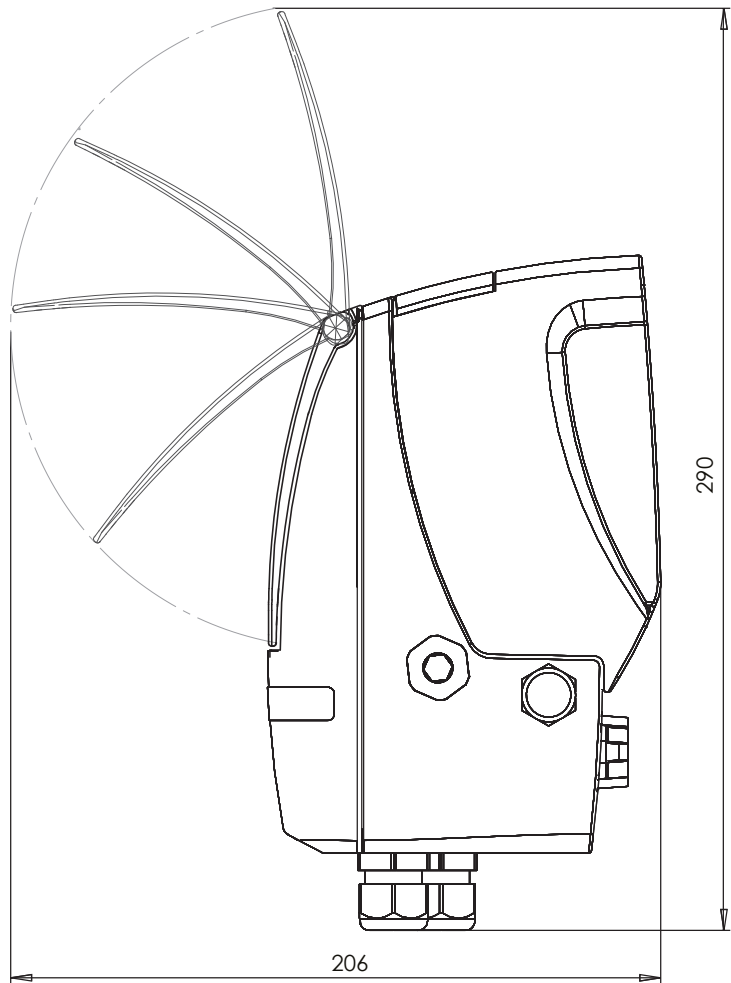
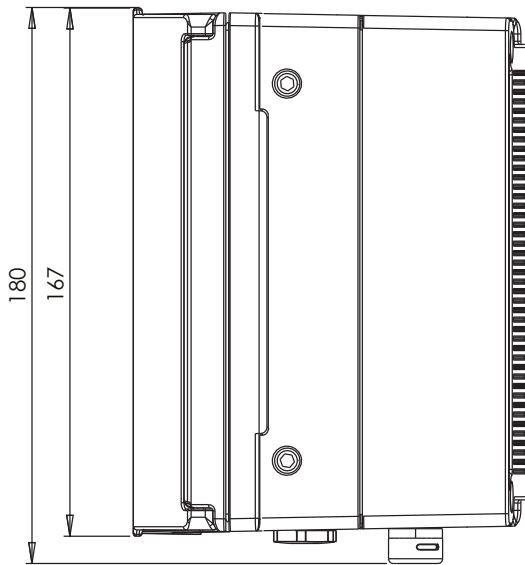
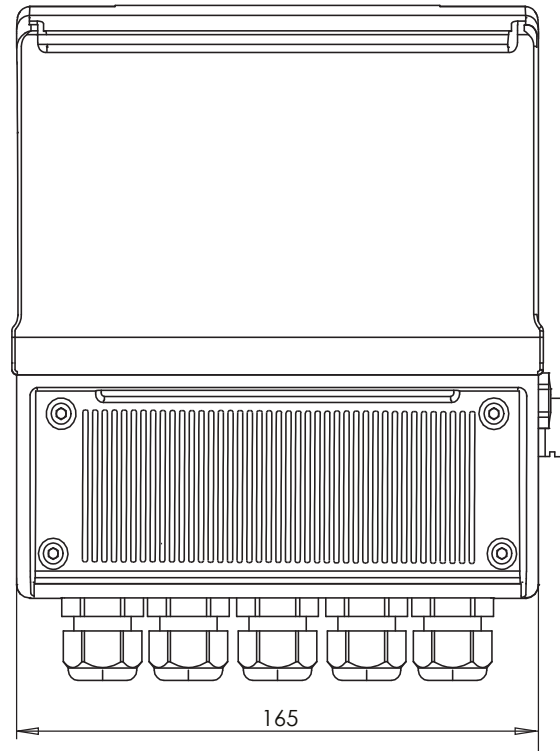
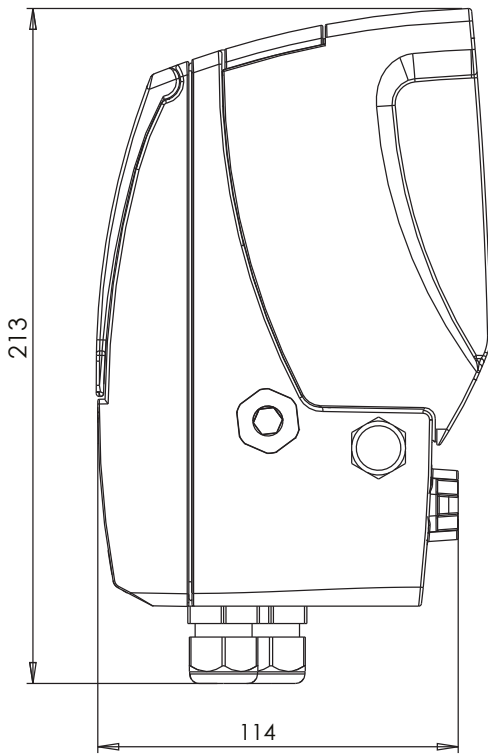

The manufacturer guarantees only English text available on our web site www.isoil.com

Horizontal compact version

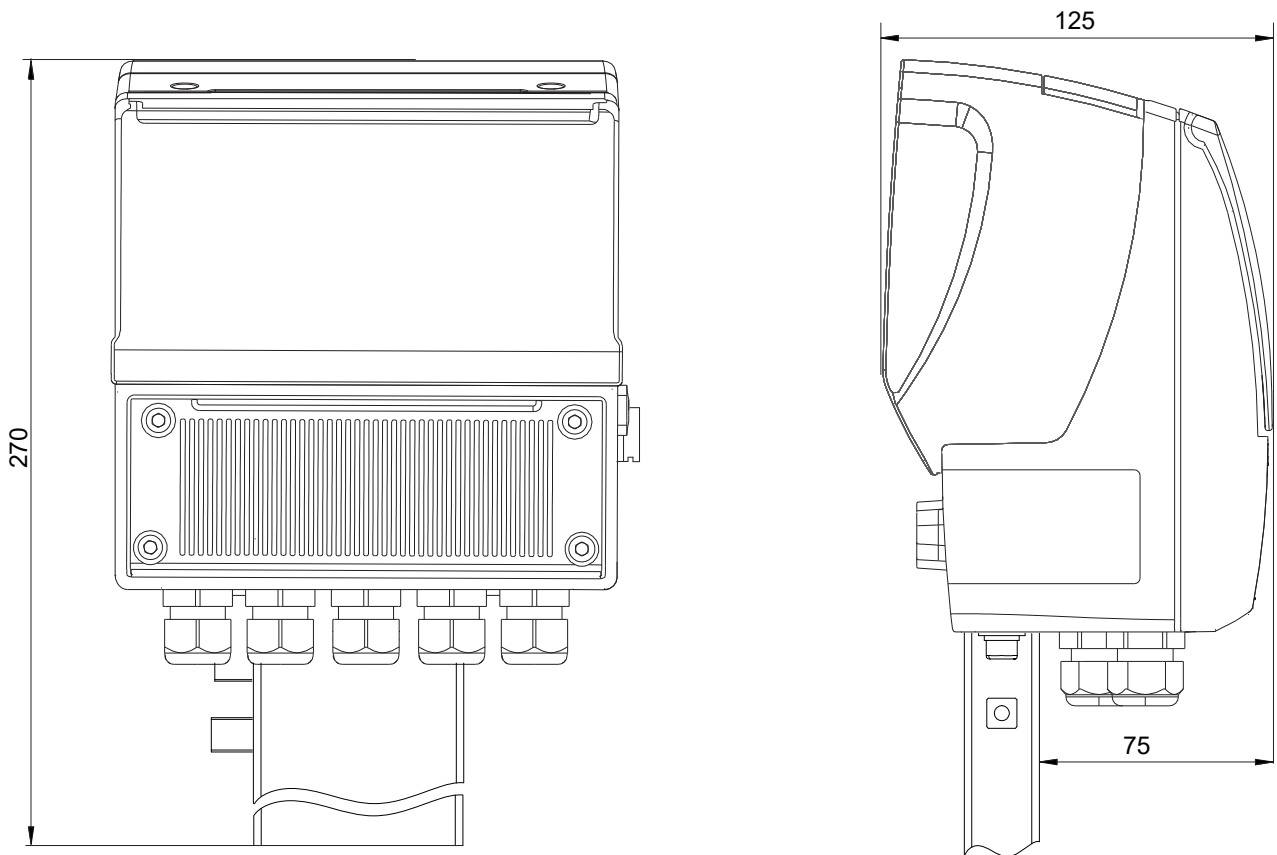

Vertical compact version

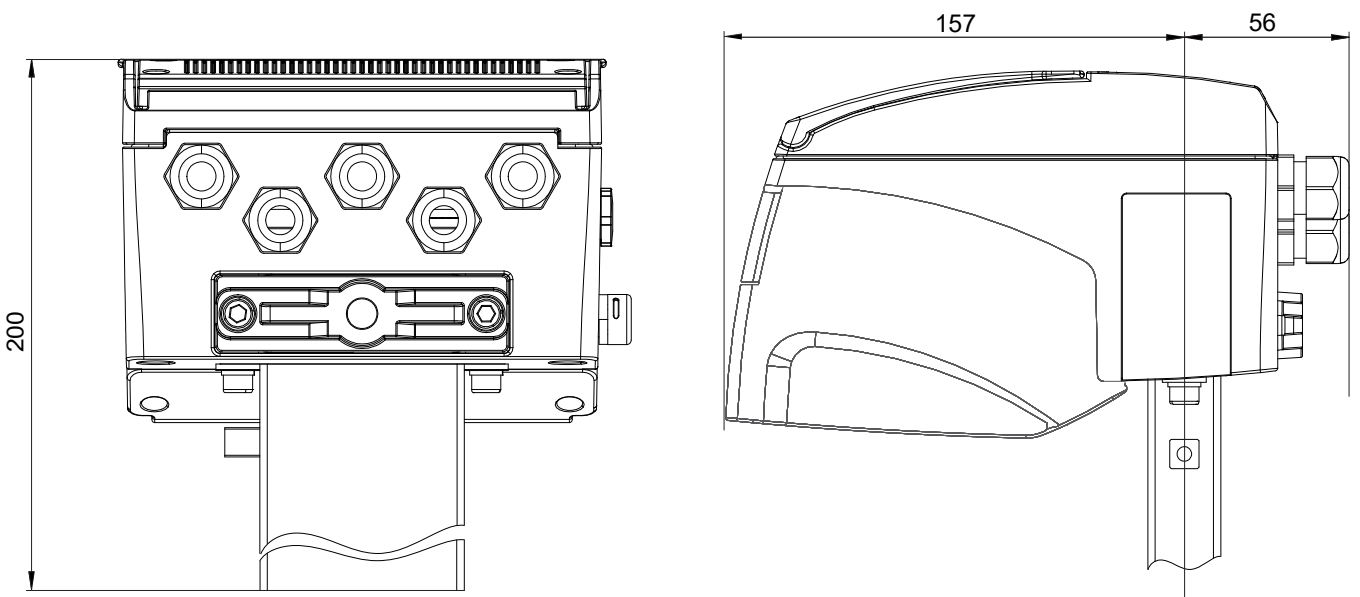

The manufacturer guarantees only English text available on our web site www.isoil.com

Separate (wall) version

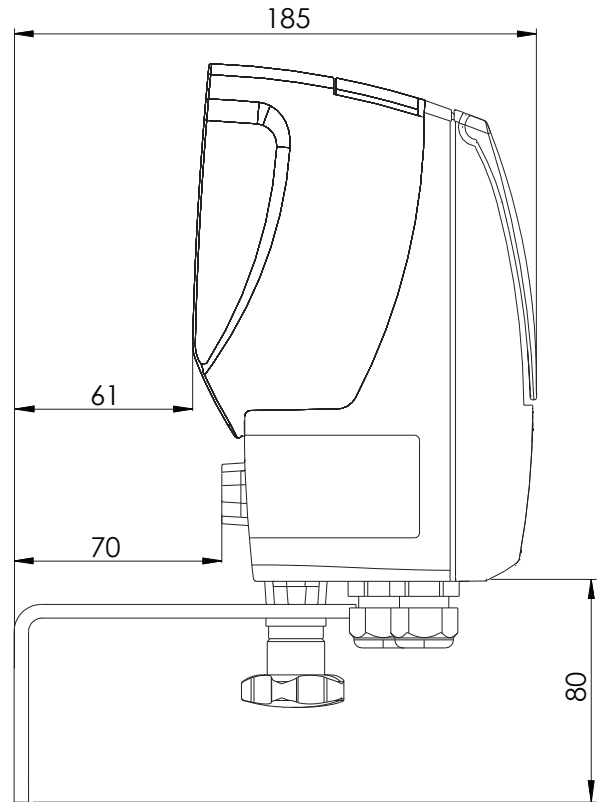
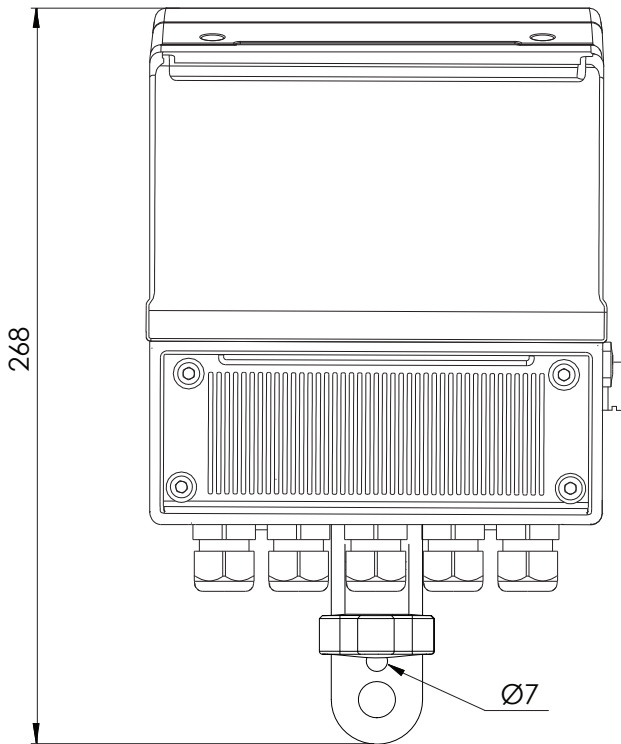

The manufacturer guarantees only English text available on our web site www.isoil.com

MV145 EXPLODED LAYOUT

TERMINAL BLOCK COVER

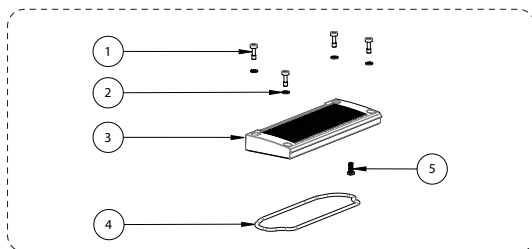

MAIN HOUSING COVER

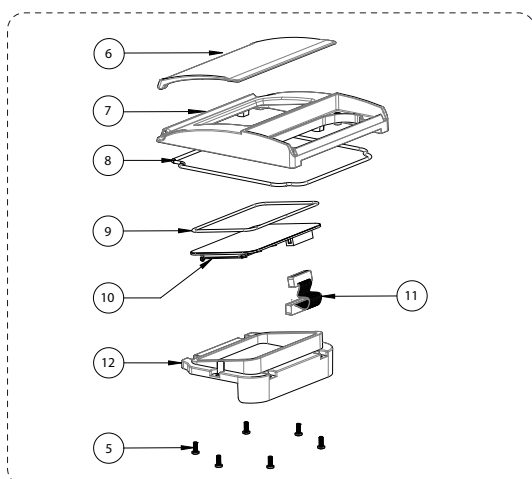

PCB MV145

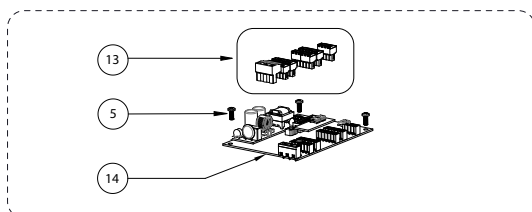

MAIN HOUSING

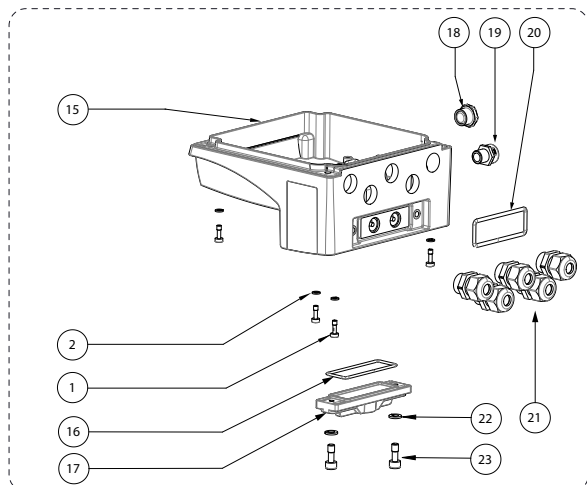

POS.	DESCRIPTION	
	PA6 VERSION	ALUMINIUM VERSION
1	SCREW M4x12	SCREW M5x12
2	GROWER WASHER Ø4	GROWER WASHER Ø5
3	TERMINAL BLOCK COVER	TERMINAL BLOCK COVER
4	O-RING-4400	
5	SELF-TAPPING SCREW 4x10	TRILOBULAR SCREW 4x10
6	PROTECTION COVER	
7	HOUSING COVER	HOUSING COVER
8	ORING-4700	
9	ORING-117x3	
10	DISPLAY	
11	FLAT CABLE	
12	PA6 FIXING DISPLAY FRAME	
13	TERMINAL BLOCK SOLID WIRE: 26-16 AWG / 0.129-1.31 mm ² STRANDED WIRE: 26-16 AWG / 0.129-1.31 mm ² TORQUE: 3.0 Lb.In / 0.34 Nm	
14	PCB MV145	
15	MAIN HOUSING	MAIN HOUSING
16	O-RING-155	
17	PA6 VERSION CAP	
18	PG9 CAP	
19	ANTICONDESE CAP	
20	O-RING-155	
21	PG11 CABLE GLAND CABLE DIAMETER: Ø5-Ø10mm	
22	GROWER WASHER Ø6	
23	SCREW M6x16	

BATTERIES HOUSING

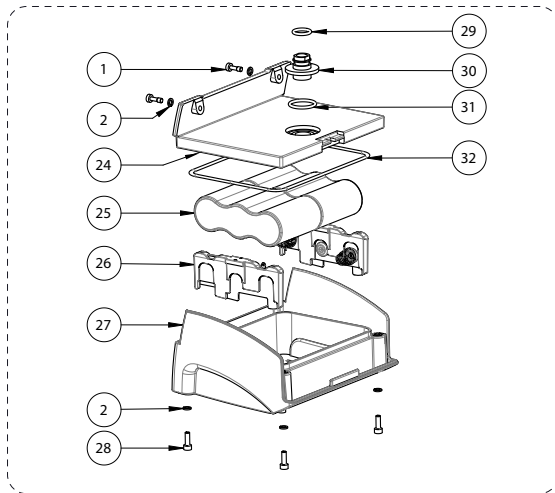

POS.	DESCRIPTION	
	PA6 VERSION	ALUMINIUM VERSION
24	PA6 BATTERY HOUSE COVER	
25	LITHIUM OR ALKALINE BATTERY	
26	CONTACTS FRAME FOR ALKALINE BATTERY	
27	PA6 BATTERY HOUSE	
28	SCREW M4X12	
29	O-RING 3050	
30	SEAL BUSH	
31	O-RING 3081	
32	O-RING 4575	

The manufacturer guarantees only English text available on our web site www.isoil.com

CONVERTER ACCESS

USB Connection

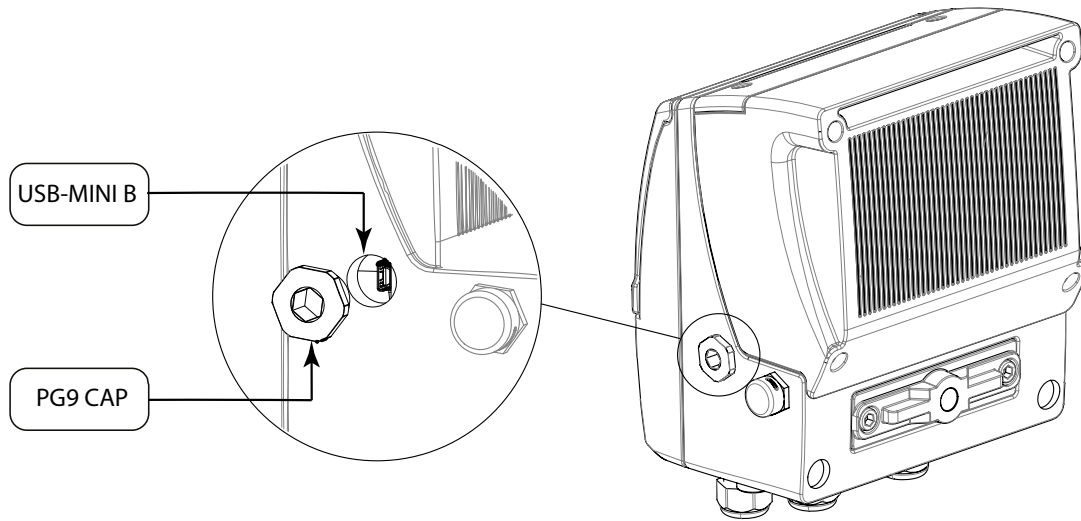

SD Card

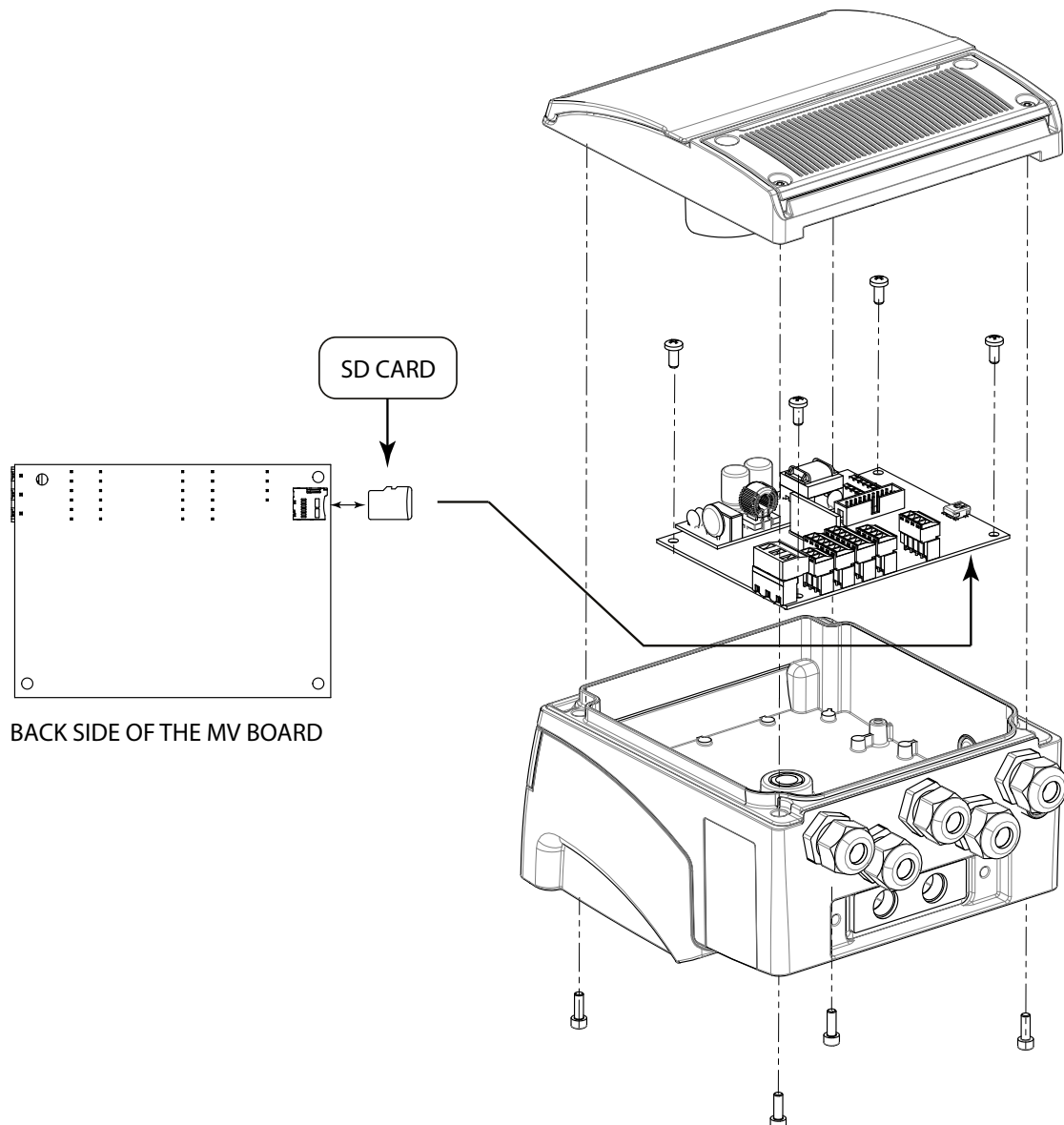

The manufacturer guarantees only English text available on our web site www.isoil.com

BATTERY POWER SUPPLY

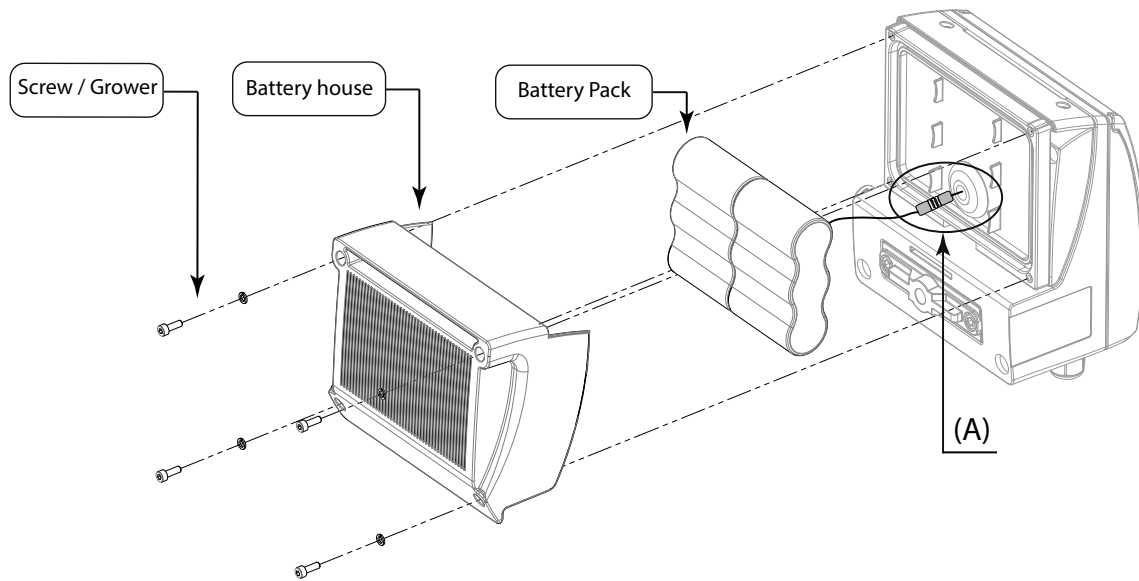

DETAIL (A) BATTERY CONNECTIONS CONVERTER PCB

LITHIUM BATTERIES

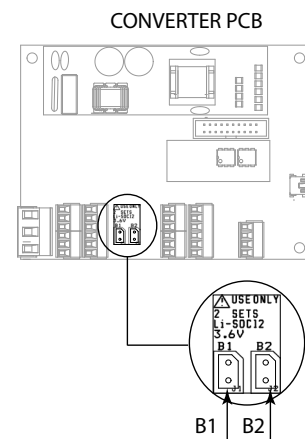
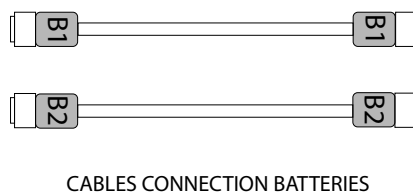
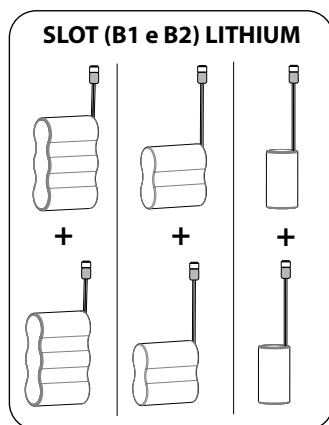

ALKALINE BATTERIES

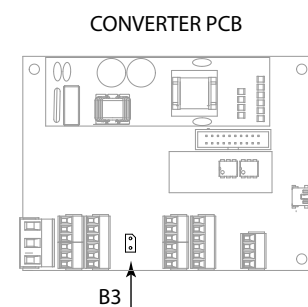
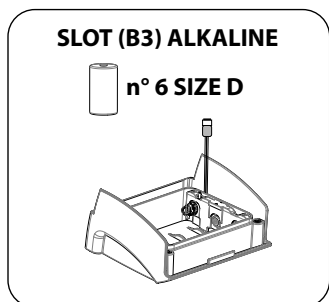

- The maximum number of batteries allowed in the various configurations is 6 size D batteries
- Alkaline batteries can also be purchased separately from third parties
- Lithium batteries are supplied exclusively by the manufacturer and can not be purchased separately from third parties. Furthermore, they are subject to special transport regulations based on the "Dangerous Goods Regulations, UN3090 and UN 3091". Special documentation is required to observe the regulations.

MAIN POWER SUPPLY

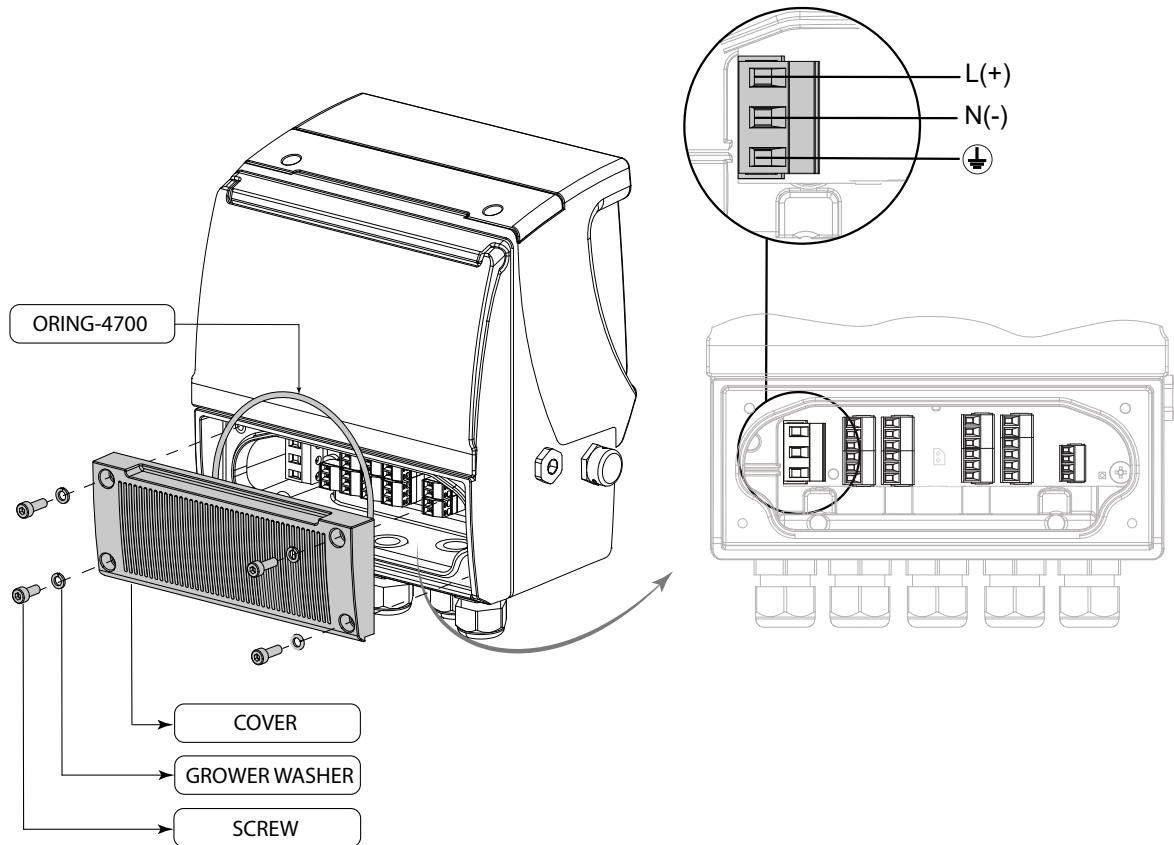

- ❑ The connections are made with approved cables with flame retardant properties, whose section varies from 0.25 mm² to 2.50 mm², based on distance / power.
- ❑ The wiring can be checked by unscrewing the 4 screws on the terminal cover.
- ❑ When the lid is raised, the terminal block is visible. The terminal block shows the wired connection of the converter to external devices, sensor included.

ELECTRICAL CONNECTIONS

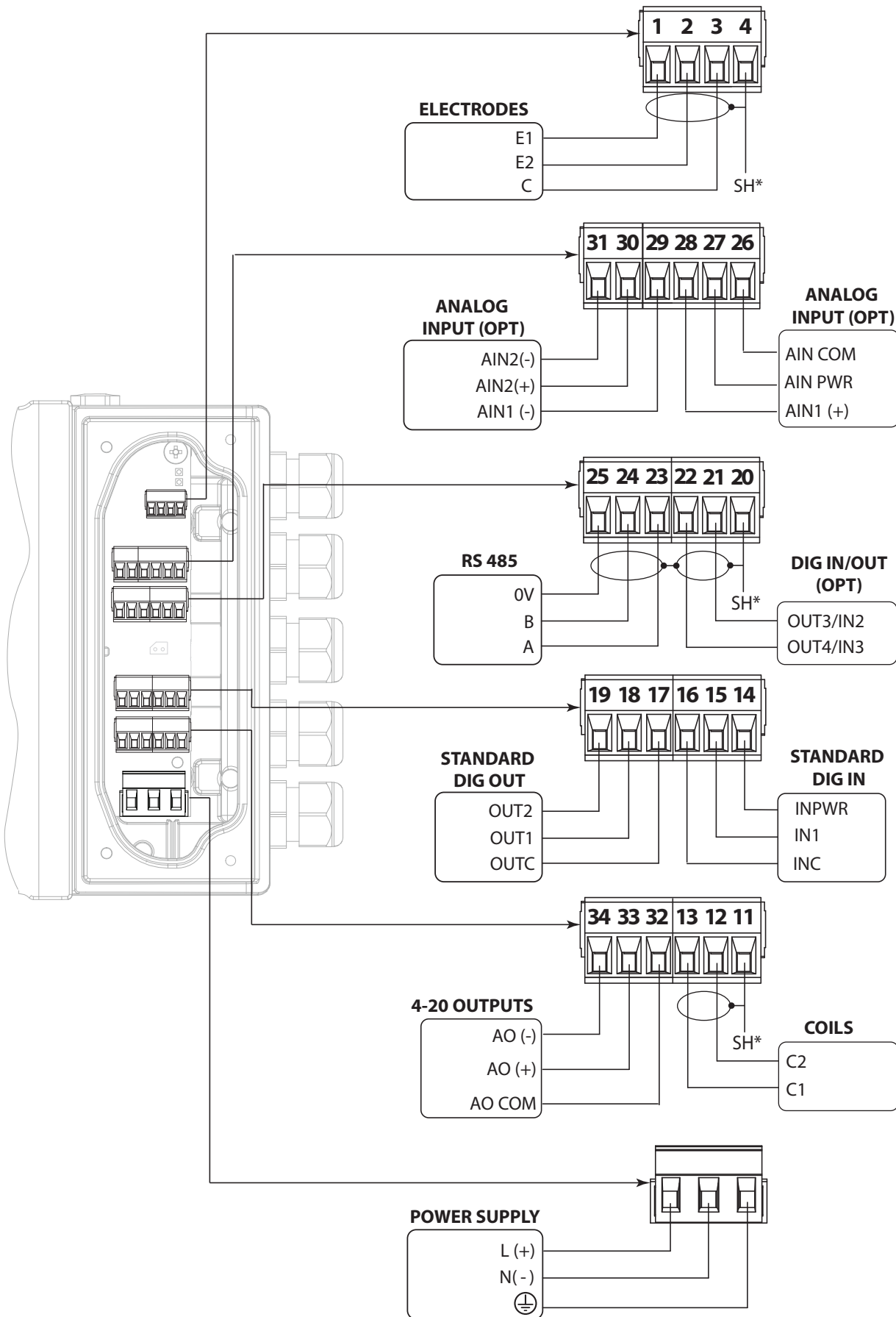

The manufacturer guarantees only English text available on our web site www.isoil.com

FUNCTIONS MENU

Pressure and temperature probes

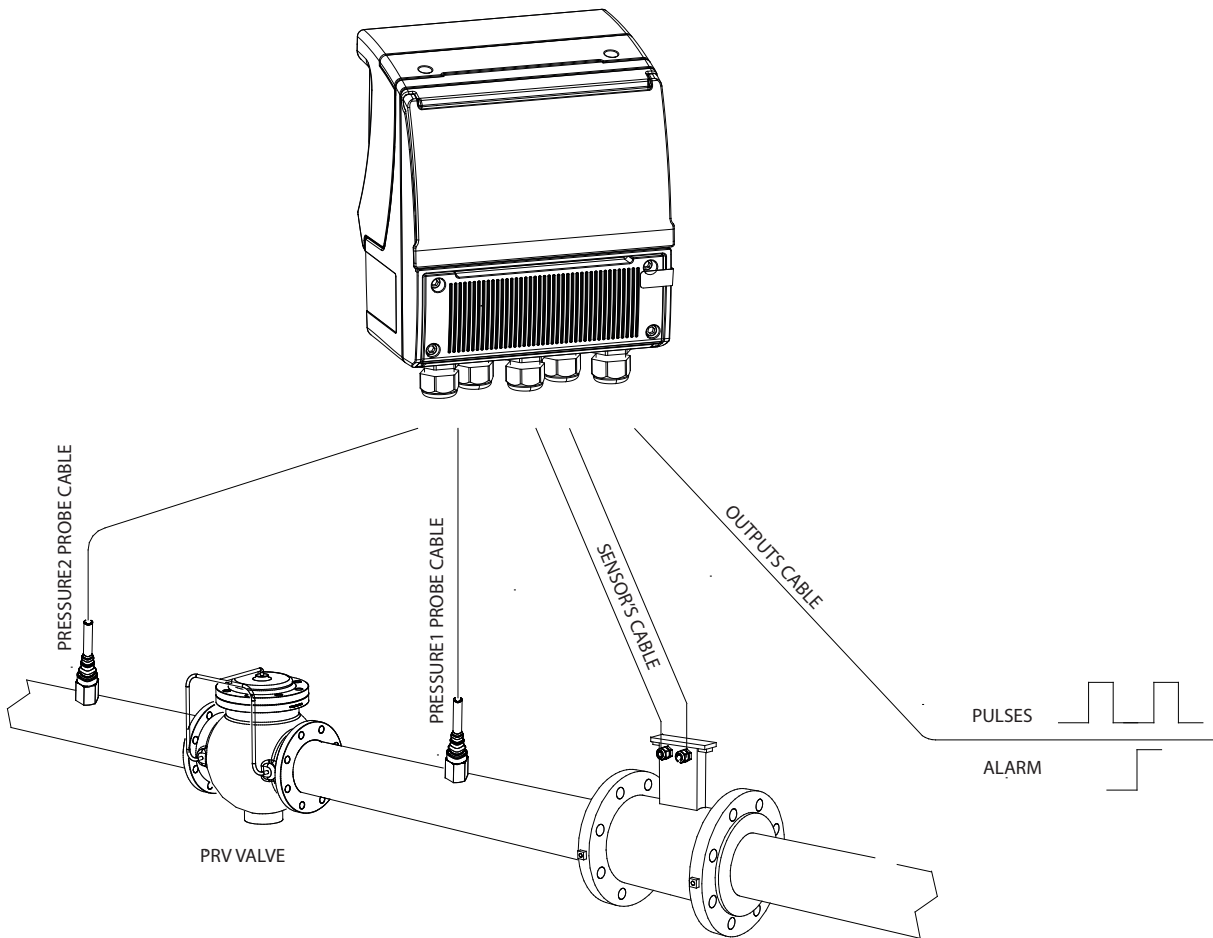

IP68 connection (example installation)

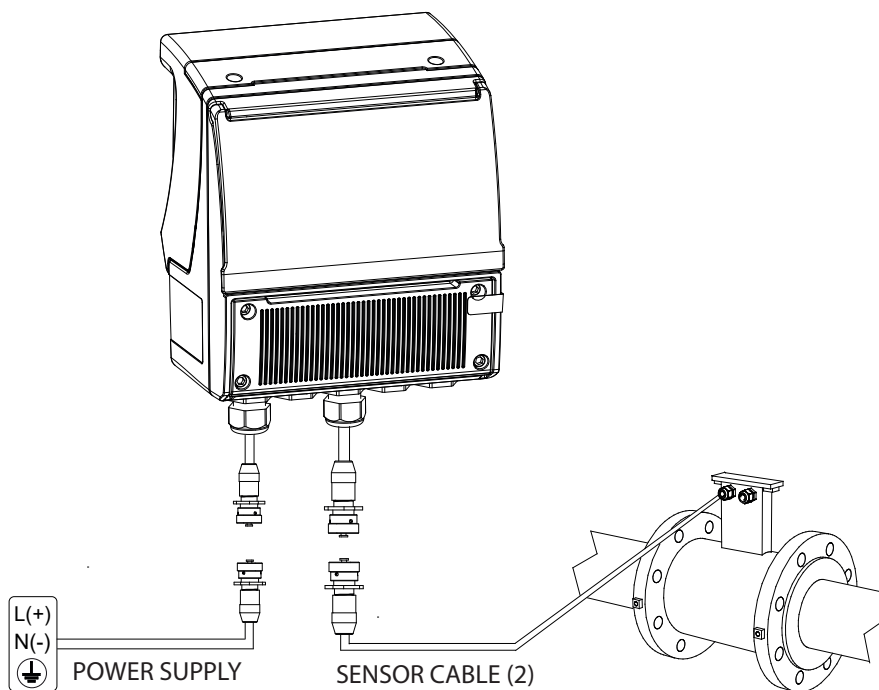

The manufacturer guarantees only English text available on our web site www.isoil.com

DIGITAL INPUTS

On / Off Input (External power supply)

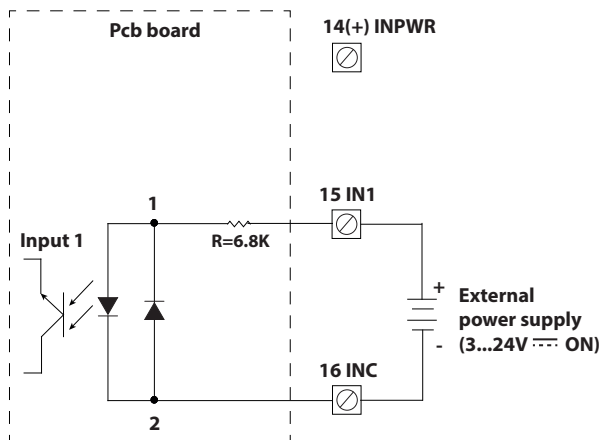

DIGITAL OUTPUTS

NOTE: the outputs are NOT polarized, so you can adopt schemes for connection to positive or common negative, as in the following electrical scheme.

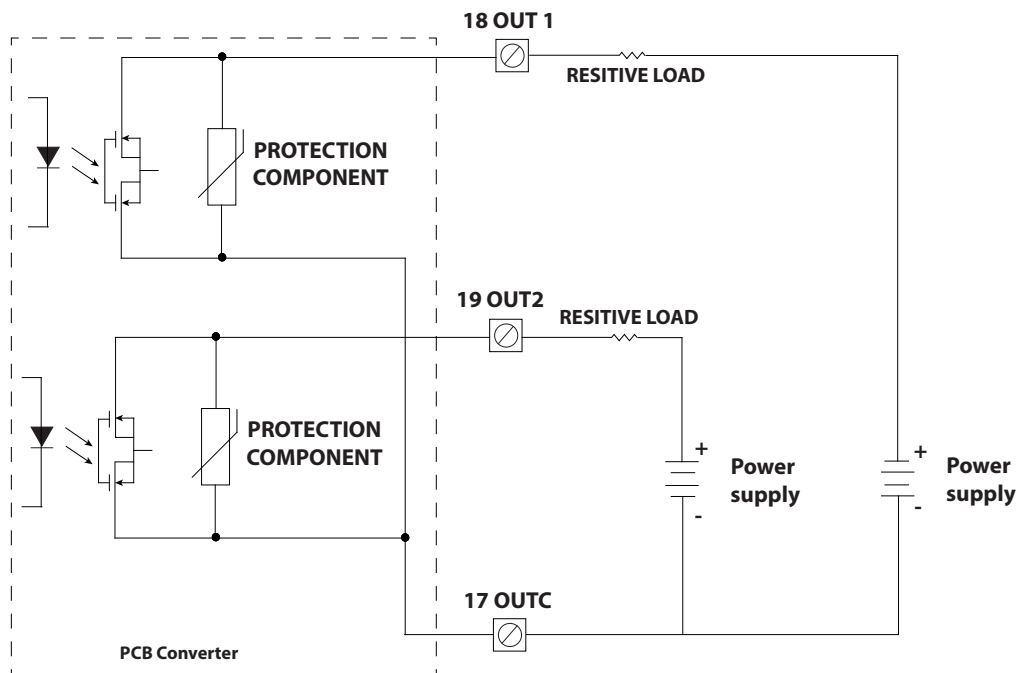

AUXILIARY MODULE ANALOG INPUTS

Connection of pressure sensors

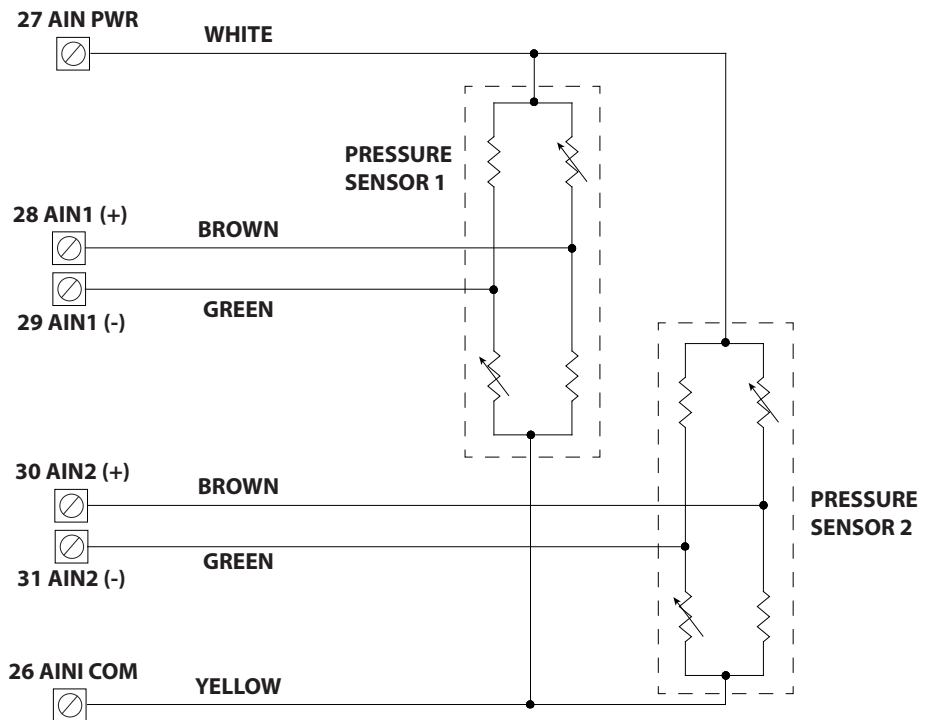

Connection of temperature sensors

There is no compensation of cable resistance, we recommend the use of PT500 or PT1000 sensors if the cable length is more than one meter. The recognition of the sensor type (PT100 / 500/1000) is automatic.

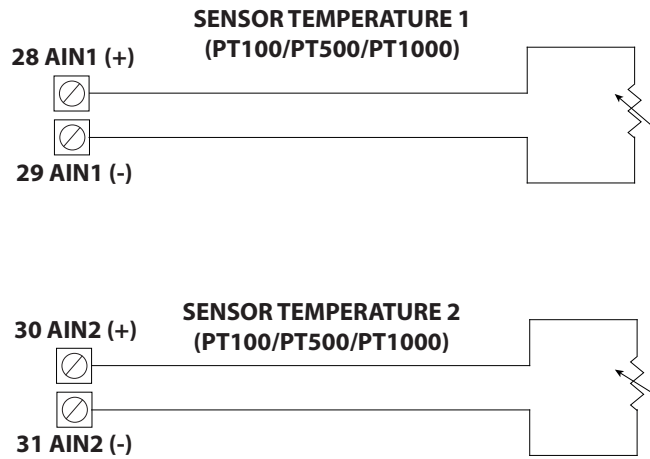

Connection of a pressure/temperature sensor

Two different types of sensors can be connected, a pressure sensor and a temperature sensor.

For the temperature sensor, because there is no compensation of cable resistance, we recommend the use of PT500 or PT1000 sensors if the cable length is more than one meter. The recognition of the sensor type (PT100 / 500/1000) is automatic.

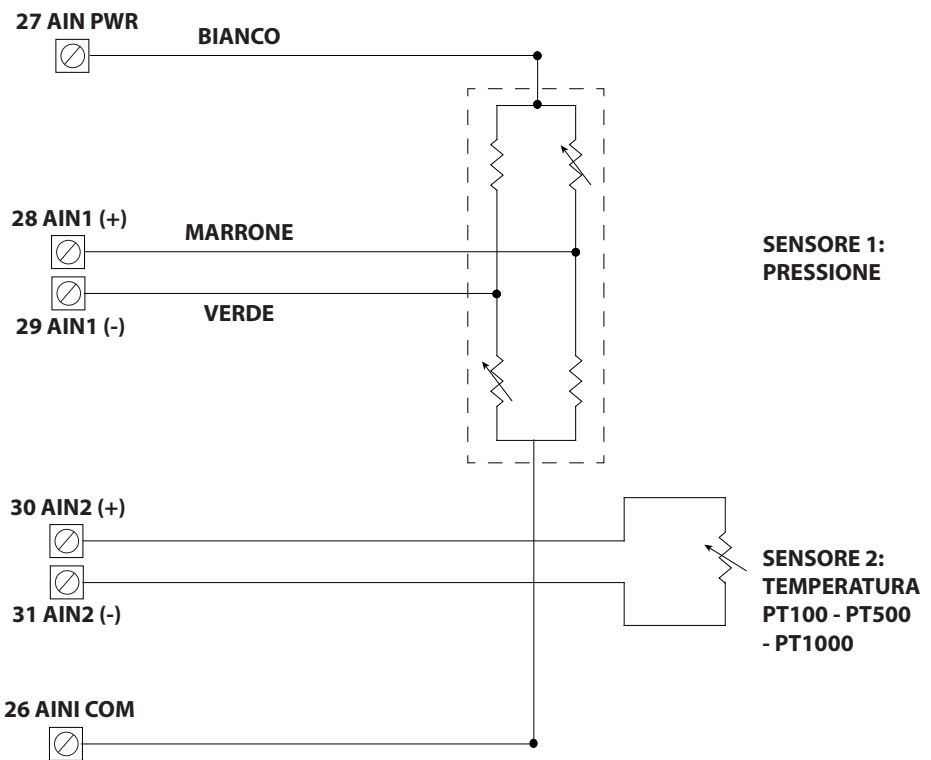

N.B: the pressure sensor MUST BE connected to input 1 and the temperature sensor MUST BE connected to Input 2!

4÷20 MA OUTPUTS

Digital input / output terminal block of the add-on module. (22-OUT4 22-IN2, 21-OUT3 21-IN3, GND):

Passive mode: power is supplied from an external source.

- Connect the POSITIVE of the external source to the AO + terminal
- Connect the LOAD to the AO- terminal

Active mode: power is supplied from the board power supply (if fitted).

- Connect the LOAD to the AO- terminal
- Connect the RETURN to the AOC terminal.

Active Connection

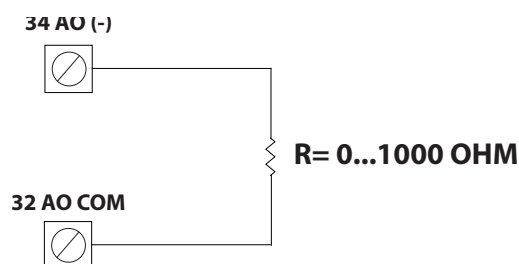

Passive Connection 1

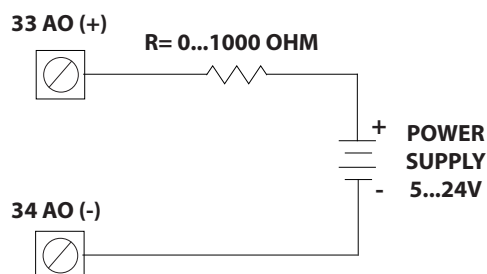

Passive Connection 2

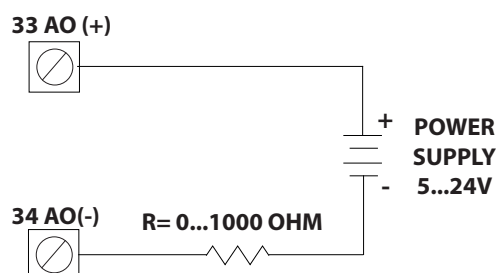

MODBUS (RS485)

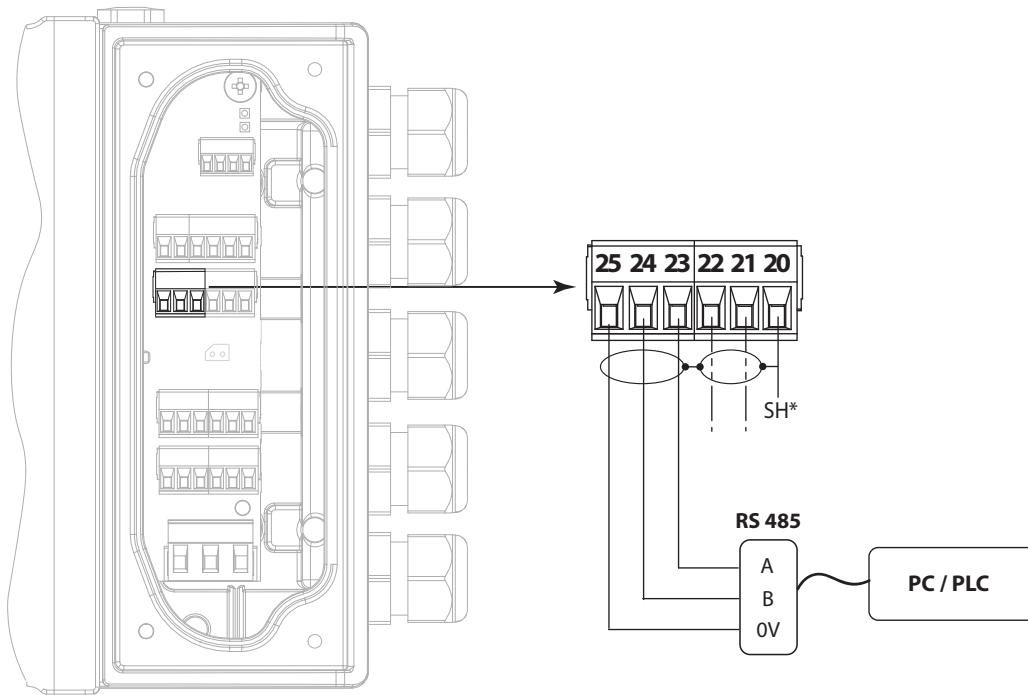

The manufacturer guarantees only English text available on our web site www.isoil.com

AUXILIARY MODULE DIGITAL INPUTS/ OUTPUTS

Digital inputs / outputs terminal block of the add-on module (22-OUT4 22-IN2, 21-OUT3 21-IN3, GND):

- ❑ 21-OUT3 21-IN3: digital output OUT 3 / digital input INPUT 3
- ❑ 22-OUT4 22-IN2: digital output OUT 4 / digital input INPUT 2
- ❑ GND: terminal connected to the protective earth (chassis) for connecting cable screens

NOTE:

- ❑ The digital outputs OUT4 and OUT3 use the 17-OUTC terminal as common.
- ❑ The digital inputs IN2 and IN3 use the 16-INC terminal as common.
- ❑ The digital output OUT4 and the digital input IN2 as well as the digital output OUT3 and the digital input IN3 share the same terminal but have different common, so the input and output circuits can be realized independently on the other hand, as indicated in the following diagram for OUT3 / IN3 (OUT4 / IN2 are equivalent).

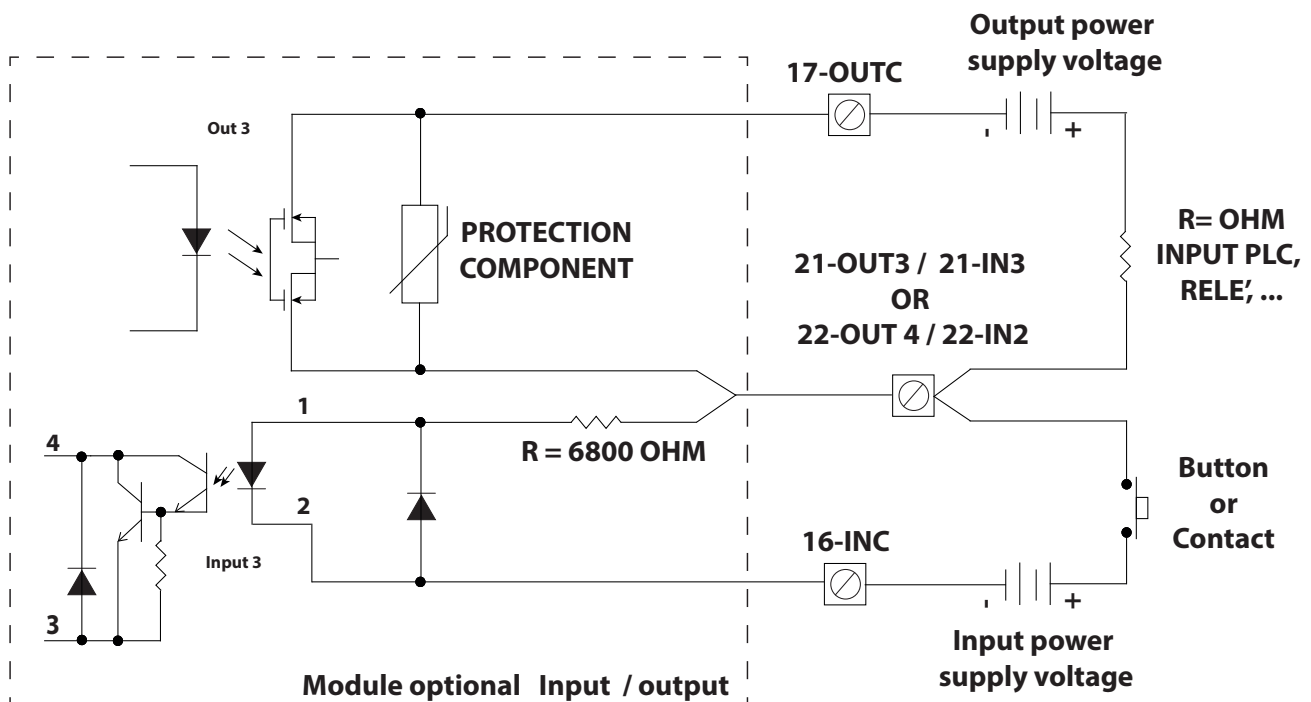

FUNCTIONS MENU

SENSOR

MAIN MENU	
1-Sensor	
2-Units	
3-Scales	
4	
5	
6	
7	
8	
9	
0	
10	
11	
12	
13	
14	
15	
16	
17	
18	
19	
20	
21	
22	
23	
24	
25	
26	
27	
28	
29	
30	
31	
32	
33	
34	
35	
36	
37	
38	
39	
40	
41	
42	
43	
44	
45	
46	
47	
48	
49	
50	
51	
52	
53	
54	
55	
56	
57	
58	
59	
60	
61	
62	
63	
64	
65	
66	
67	
68	
69	
70	
71	
72	
73	
74	
75	
76	
77	
78	
79	
80	
81	
82	
83	
84	
85	
86	
87	
88	
89	
90	
91	
92	
93	
94	
95	
96	
97	
98	
99	
100	

SENSOR	
S.model	0
Lining	UNSPEC.
S.type	FULLBORE
U.type	METRIC
Diam.	00700
KA	+00.9637
KA-	-44904
KZ	-18852
KD	+00.4014
Ins.position	0
KP dynamic	OFF
Ki	10000
Kp	10000
KC	100000
C.Curr.	mA025.0
C.Reg. PB	ms03
C.Reg.DH	stp 005
C.R.time	ms03
E.P.Detect	ON
Z max	Hohm 0500
S.err.delay	10
Sens.verify	OFF
KL	00.+000000
Zero point cal.	

- 1.1 Sensors model: Enter the first two characters of the serial number of the sensor
- 1.2 Flow sensor lining material type
- 1.3 Type of sensor: fullbore or insertion
- 1.4 Type of measure units for sensor parameter: metric or imperial
- 1.5 Sensor's nominal/real diameter DN (0-2500)
- 1.6 Sensor coefficient KZ (zero point)
- 1.7 Calibration data of sensor for negative flow
- 1.8 Sensor coefficient KZ (zero point)
- 1.9 Sensor coefficient KD
- 1.10 Insertion position
- 1.11 KP dynamic, coefficient for insertion
- 1.12 Sensor coefficient Ki
- 1.13 Sensor coefficient Kp
- 1.14 Sensor coefficient KC
- 1.15 Sensor excitation current
- 1.16 Current regulator proportional band
- 1.17 Current regulator derivation constant
- 1.18 Measure sampling frequency
- 1.19 Enables the empty pipe detection feature
- 1.20 Empty pipe detection threshold
- 1.21 Signal error delay (n. sample)
- 1.22 Automatic sensor verify enable
- 1.23 Linearization coefficient
- 1.24 Pipe hydraulic zero calibration

UNITS

MAIN MENU	
1-Sensor	
2-Units	
3-Scales	
4	
5	
6	
7	
8	
9	
0	
10	
11	
12	
13	
14	
15	
16	
17	
18	
19	
20	
21	
22	
23	
24	
25	
26	
27	
28	
29	
30	
31	
32	
33	
34	
35	
36	
37	
38	
39	
40	
41	
42	
43	
44	
45	
46	
47	
48	
49	
50	
51	
52	
53	
54	
55	
56	
57	
58	
59	
60	
61	
62	
63	
64	
65	
66	
67	
68	
69	
70	
71	
72	
73	
74	
75	
76	
77	
78	
79	
80	
81	
82	
83	
84	
85	
86	
87	
88	
89	
90	
91	
92	
93	
94	
95	
96	
97	
98	
99	
100	

UNITS	
Diam.	mm
S.cable	m
FR.unit	METRIC
Pls1 u.	METRIC
Pls2 u.	METRIC
T+ unit	METRIC
T+ unit	(m3)
T+ D.P.	4
P+ unit	METRIC
P+ unit	(m3)
P+ D.P.	4
T- unit	METRIC
T- unit	(m3)
T- D.P.	4
P- unit	METRIC
P- unit	(m3)
P- D.P.	4
Temp.unit	°C
Mass units	ON
Sg	(kg/dm3)
AIN1 m.u.	1.107MCPI
AIN2 m.u.	1.107MCPI

- 2.1 Nominal diameter measure unit
- 2.2 Cable length on separate version
- 2.3 Flow rate type measure unit: metric or imperial
- 2.4 Pulse 1 type measure unit: metric or not metric
- 2.5 Pulse 2 type measure unit: metric or not metric
- 2.6 Total direct totalizer measure unit type: metric or imperial
- 2.7 Total direct totalizer measure unit
- 2.8 Total direct totalizer decimal point position
- 2.9 Partial direct totalizer measure unit type: metric or not metric
- 2.10 Partial direct totalizer measure unit
- 2.11 Partial direct totalizer decimal point position
- 2.12 Total reverse totalizer measure unit type: metric or not metric
- 2.13 Total reverse totalizer measure unit
- 2.14 Total reverse totalizer decimal point position
- 2.15 Partial reverse totalizer measure unit type: metric or not metric
- 2.16 Partial reverse totalizer measure unit
- 2.17 Partial reverse totalizer decimal point position
- 2.18 Temperature measure
- 2.19 Enable/disable the selection of mass units on full scale set
- 2.20 Specific gravity coefficient
- 2.21 Unit of measurement for analogue input 1
- 2.22 Unit of measurement for analogue input 2

SCALES

MAIN MENU		
1	Sensor	
2	Units	
3	Scale	
4	Measure	
5	Alarms	
6	Inputs	
7	Calibration	
8	Factory	
9	Help	
0	Exit	
1	0000	
1	1111	
1	2222	
1	3333	
1	4444	
1	5555	
1	6666	
1	7777	
1	8888	
1	9999	
1	0000	

SCALES				
FS1	dm3/s	5.00	3.1	Full scale flow rate 1
Pls1	dm3	0.15	3.2	Full scale flow rate 2
Tpls1		(ms)	3.3	Duration of the pulse generated on channel 1
Pls2	dm3	0.15	3.4	Pulse value on channel 2
Tpls2		15*(ms)	3.5	Duration of the pulse generated on channel 2
AIN1		1,107/MCPI	3.6	Analog input scale 1
AIN2		1,107/MCPI	3.7	Analog input scale 2

MEASURE

MAIN MENU		
1	Sensor	
2	Units	
3	Scale	
4	Measure	
5	Alarms	
6	Inputs	
7	Calibration	
8	Factory	
9	Help	
0	Exit	
1	0000	
1	1111	
1	2222	
1	3333	
1	4444	
1	5555	
1	6666	
1	7777	
1	8888	
1	9999	
1	0000	

MEASURE				
Filt.bypass		ON	4.1	Measure filter bypass
Cut-off		00.0(%)	4.2	Measure cut-off threshold
Cal.verify		ON	4.3	Automatic calibration verify
H.imm.inp.		ON	4.4	High immunity inputs

ALARMS

MAIN MENU		
1	Sensor	
2	Units	
3	Scale	
4	Measure	
5	Alarms	
6	Inputs	
7	Calibration	
8	Factory	
9	Help	
0	Exit	
1	0000	
1	1111	
1	2222	
1	3333	
1	4444	
1	5555	
1	6666	
1	7777	
1	8888	
1	9999	
1	0000	

ALARMS				
Max+	dm3/s	OFF	5.1	Max.pos.flow r.alarm threshold MAX+
Max-	dm3/s	OFF	5.2	Max.neg.flow r.alarm threshold MAX-
Min+	dm3/s	OFF	5.3	Min.pos.flow r.alarm threshold MIN+
Min-	dm3/s	OFF	5.4	Min.neg.flow r.alarm threshold MIN-
Qhyst		XXXXX	5.5	Hysteresis on f.rate alarm threshold
A1Mx		()	5.6	MAX alarm threshold for analog input 1
A1Mn		()	5.7	MIN alarm threshold for analog input 1
Ai1H	HPa	0.00	5.8	AIN1 MIN alarm threshold
A2Mx		()	5.9	MAX alarm threshold for analog input 2
A2Mn		()	5.10	MIN alarm threshold for analog input 2
Ai2H	HPa	0.00	5.11	Hysteresis on a. in.2 al. thr

INPUTS

```

MAIN MENU
1-Sensor
2-Units
3-Scales
4-Measure
5-Alarms
6-Inputs
7-Outputs
8-Communication
9-Display
10-Data logger
11-Functions
12-Diagnostic
13-System
    
```

```

10-Inputs
11-
12-
13-
INPUTS
T+ reset          OFF
P+ reset          OFF
T- reset          OFF
P- reset          OFF
Count lock        OFF
Meas.lock         OFF
Calibration       OFF
Sys.v.detect      ON
D.In2             SYS.UOL.
D.In3             OFF
D.in p.sup        ON
    
```

6.1 Total direct (positive) flow totalizer reset enable
 6.2 Partial direct (positive) flow totalizer reset enable
 6.3 Total reverse (negative) flow totalizer reset enable
 6.4 Partial reverse (negative) flow totalizer reset enable
 6.5 Totalizer counting lock command
 6.6 Measure zero lock command
 6.7 Calibration external command
 6.8 System violation detect
 6.9 Digital input 2 function
 6.10 Digital input 3 function
 6.11 Digital auxiliary input power supply.

OUTPUTS

```

OUTPUTS
Out1              F.R.SIGN
Out1 inv.         ON
Out1 pls.         ON
Out2              ANL.MK/MN
Out2 inv.         ON
Out2 pls.         ON
Out3              MAH.AL+
Out3 inv.         ON
Out3 pls.         ON
Out4              MAH.AL+
Out4 inv.         ON
Out4 pls.         ON
Out mA1           Apr-20
A1S              dm3/s
    
```

7.1 Output 1 function selection
 7.2 Output 1 inverted status
 7.3 Output 1 pulsed status
 7.4 Output 2 function selection
 7.5 Output 2 inverted status
 7.6 Output 2 pulsed status
 7.7 Output 3 function selection
 7.8 Output 3 inverted status
 7.9 Output 3 pulsed status
 7.10 Output 4 function selection
 7.11 Output 4 inverted status
 7.12 Output 4 pulsed status
 7.13 Analog current output 1 range
 7.14 Full scale value for analog out1

```

MAIN MENU
1-Sensor
2-Units
3-Scales
4-Measure
5-Alarms
6-Inputs
7-Outputs
8-Communication
9-Display
10-Data logger
11-Functions
12-Diagnostic
13-System
    
```

COMMUNIC.

```

COMMUNICATIONS
Dev. Addr.        1
Speed             bps22800
Parity            NO
Delay             ms 00
C.timeout         2
    
```

8.1 Device communication address number
 8.2 MODBUS link speed
 8.3 MODBUS link parity
 8.4 MODBUS reply delay
 8.5 Max.delay between chars (frame)

```

MAIN MENU
1-Sensor
2-Units
3-Scales
4-Measure
5-Alarms
6-Inputs
7-Outputs
8-Communication
9-Display
10-Data logger
11-Functions
12-Diagnostic
13-System
    
```

DISPLAY

DISPLAY			
Language	EN	9.1	Language for all messages
Disp.time	s	9.2	Display/keyboard inactivity time
D.rate		9.3	Display refresh rate
Disp.Fn.	1	9.4	Display function number
Disp.lock	OFF	9.5	Display function selection lock
Part.tot.	ON	9.6	Partial totalizers enable
Neg.tot.	ON	9.7	Negative totalizers enable
Net tot.	ON	9.8	Net totalizers enable
Disp.date	ON	9.9	Time and date display enable
Quick start	OFF	9.10	Quick start menu enable

DATA LOGGER

DATA LOGGER			
D.logger en.	ON	10.1	Data logger enabling
Meas.units	ON	10.2	Measure unit recording enable
Field separ.	;	10.3	Field separator character
Decim.separ.	.	10.4	Decimal separator character
Interv.	0:01:00	10.5	Sampling interval
Log T+	OFF	10.6	Totalizer Total Positive Enable T+
Log P+	OFF	10.7	Totalizer Partial Positive Enable P+
Log T-	OFF	10.8	Totalizer Total Negative Enable T-
Log P-	OFF	10.9	Totalizer Partial Net Enable P-
Log TN	OFF	10.10	Totalizer Total Net Enable
Log PN1	OFF	10.11	Totalizer Partial Net Enable
Log Q(UM)	OFF	10.12	Flow rate in Technical Units Enable
Log Q(%)	OFF	10.13	Flow rate in Percentage Enable
Log AL.EV	OFF	10.14	Alarm Events Enable
Log ADM	OFF	10.15	Additional Measures Enable
Log STR	OFF	10.16	Sensor Test Results Enable
Log BTS	OFF	10.17	Board TemperatureS Enable
Log IBV	OFF	10.18	Internal Board Voltages
Log EDC	OFF	10.19	Electrodes DC Voltages Enable
Log EAC	OFF	10.20	Electrodes AC voltages Enable
Log EIZ	OFF	10.21	Electrodes Source Impedance Enable
Log SCV	OFF	10.22	Sensor Coils Values Enable

FUNCTION

FUNCTION			
T+ reset	ON	11.1	Volume Totalizer Total Positive Reset
P+ reset	ON	11.2	Volume Totalizer Partial Positive Reset
T- reset	;	11.3	Volume Totalizer Total Negative Reset
P- reset	.	11.4	Volume Totalizer Partial Negative Reset
Load Sens.F.def	0:01:00	11.5	Load Factory Default Sensor Data
Load Conv.F.def	OFF	11.6	Load Factory Default Converter Data
Save Sens.F.def	OFF	11.7	Save Factory Default Sensor Data
Save Conv.F.def	OFF	11.8	Save Factory Default Converter Data
Calibration	OFF	11.9	CAlibration Immediate Command

DIAGNOSTIC

DIAGNOSTIC

```

Self test
Sens.verify
Flow sim. OFF
Display measures
Disp.comm.vars
SMS test
SMTP conn test
POP3 conn.test
FTP conn.test
Display graphs
SD card info
Firmware info
S/N 0
WT 000:00:00:00
TC 0
    
```

- 12.1 Auto test Immediate Command
- 12.2 Sensor Verify Command
- 12.3 Measure Simulation Enable
- 12.4 Diagnostic Measure VaLues
- 12.5 Diagnostic Communication VaLues
- 12.6 Short Message Test
- 12.7 SMTP Connection Test
- 12.8 POP3 Connection Test
- 12.9 FTP Connection Test
- 12.10 Oscilloscope function
- 12.11 SD memory Status
- 12.12 Model and Software Version
- 12.13 Serial Number
- 12.14 Total Working Time
- 12.15 Total Measure Cycles

```

MAIN
1-Inputs
2-Outputs
3-Communication
4-Display
5-Data logger
6-Functions
7-Diagnostic
8-System
    
```

SYSTEM

SYSTEM

```

Dayl.saving ON
Time zone +00.00
Date/time ///00:00:00
L1 code xxxxxxxx
L2 code xxxxxxxx
L3 code xxxxxxxx
L4 code xxxxxxxx
L5 code xxxxxxxx
L6 code xxxxxxxx
Restr.access OFF
Device IP addr 63015504
Client IP addr 11012012
Network mask 255.255.254
RT 0.97882
KS 100.000
KR 100.000
DAC1 4mA 2460
DAC1 20mA 11050
AIN1 SS 0
AIN1 FS 20000
AIN2 SS 0
AIN2 FS 20000
Stand-by
FW update
    
```

- 13.1 Daylight Saving Time Enable
- 13.2 Time zone
- 13.3 Date and Time
- 13.4 Level 1 Access CoDe
- 13.5 Level 2 Access CoDe
- 13.6 Level 3 Access CoDe
- 13.7 Level 4 Access CoDe
- 13.8 Level 5 Access CoDe
- 13.9 Level 6 Access CoDe
- 13.10 ReStricted Access Rule Enable
- 13.11 Device IP Address
- 13.12 Client IP Address
- 13.13 Network MaSk
- 13.14 Coefficient KT
- 13.15 Coefficient KS
- 13.16 Coefficient KR
- 13.17 Current output 1 Calibration Point 1
- 13.18 Current output 1 Calibration Point 2
- 13.19 Analog input 1 Calibration Point 1
- 13.20 Analog input 1 Calibration Point 2
- 13.21 Analog input 2 Calibration Point 1
- 13.22 Analog input 2 Calibration Point 2
- 13.23 System StandbY
- 13.24 Firmware update

```

MAIN
1-Inputs
2-Outputs
3-Communication
4-Display
5-Data logger
6-Functions
7-Diagnostic
8-System
    
```

MEASUREMENT SETTINGS

MV145 can be programmed to acquire the measurement in two different ways:

- ENERGY SAVING MODE: Sampling every 15 s.
- CONT. PWR: Continuous power sampling.

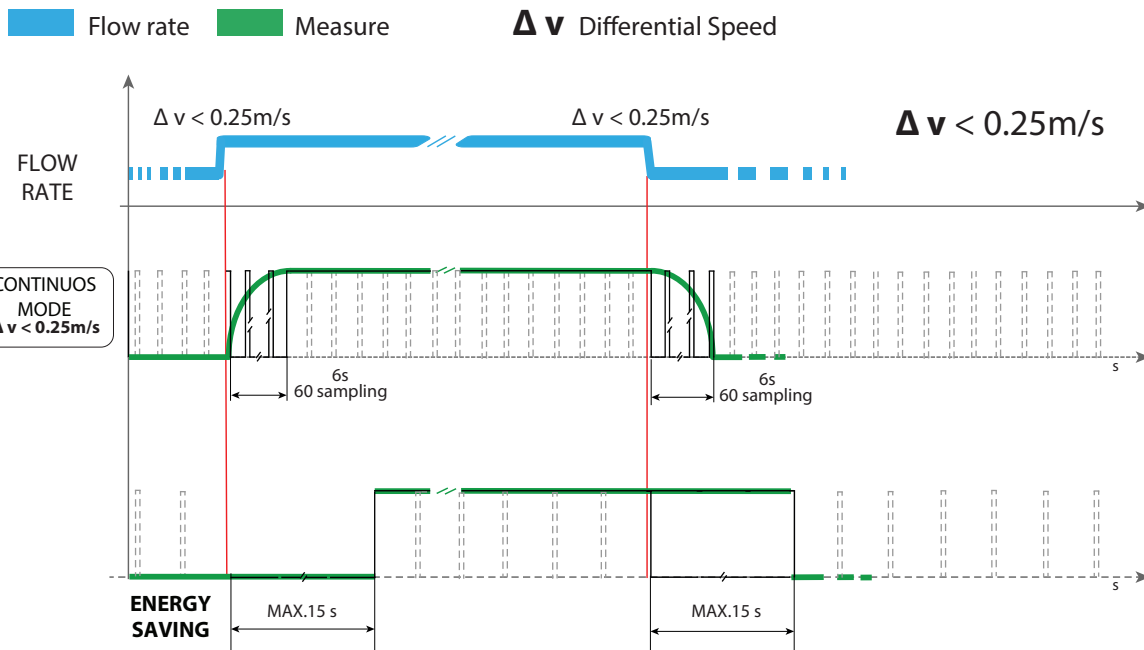
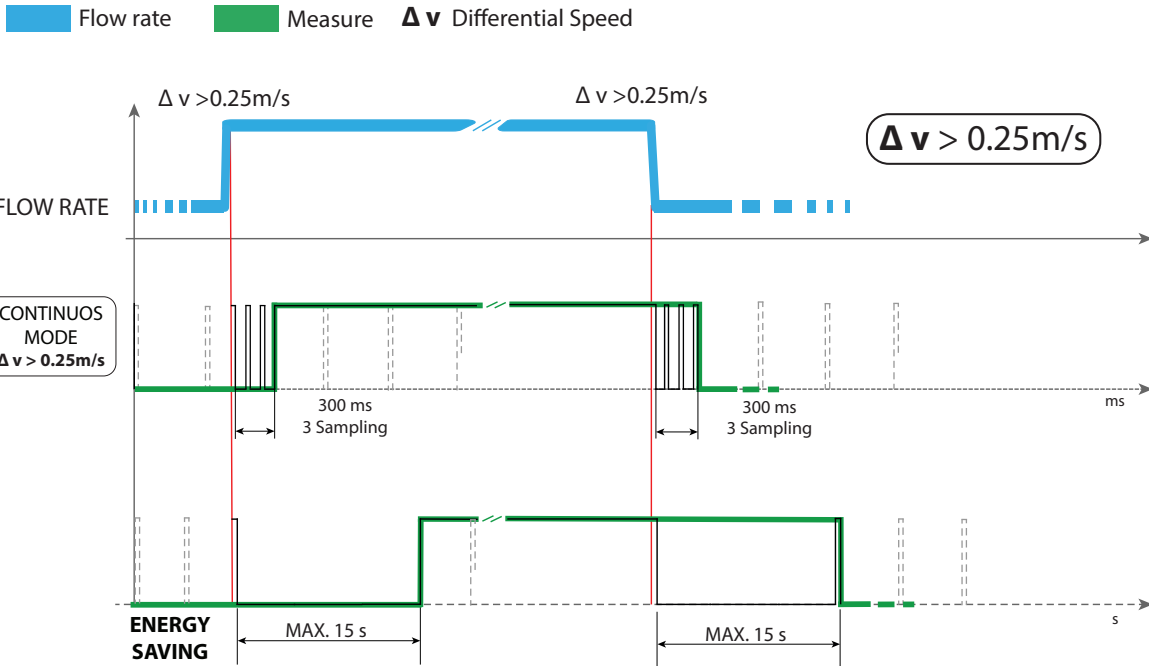

The manufacturer guarantees only English text available on our web site www.isoil.com

MAIN PAGES VISUALIZATION

Possible views by simply pressing the button

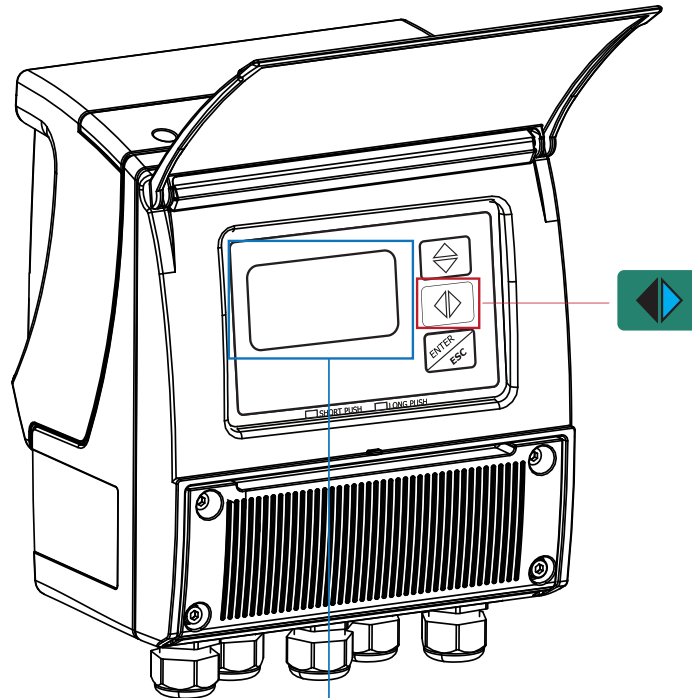

The manufacturer guarantees only English text available on our web site www.isoil.com

USER INTERFACE

Besides the keyboard, the converter can be programmed by MCP INTERFACE: a real time interface between converter and PC.

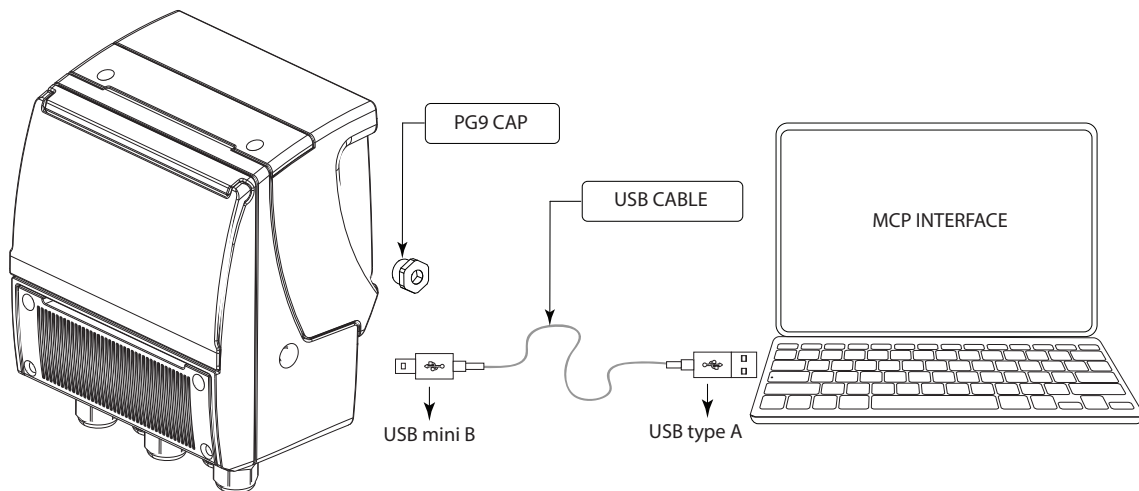
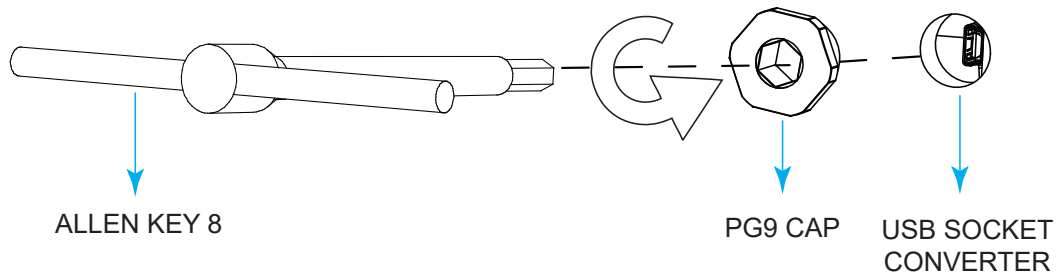
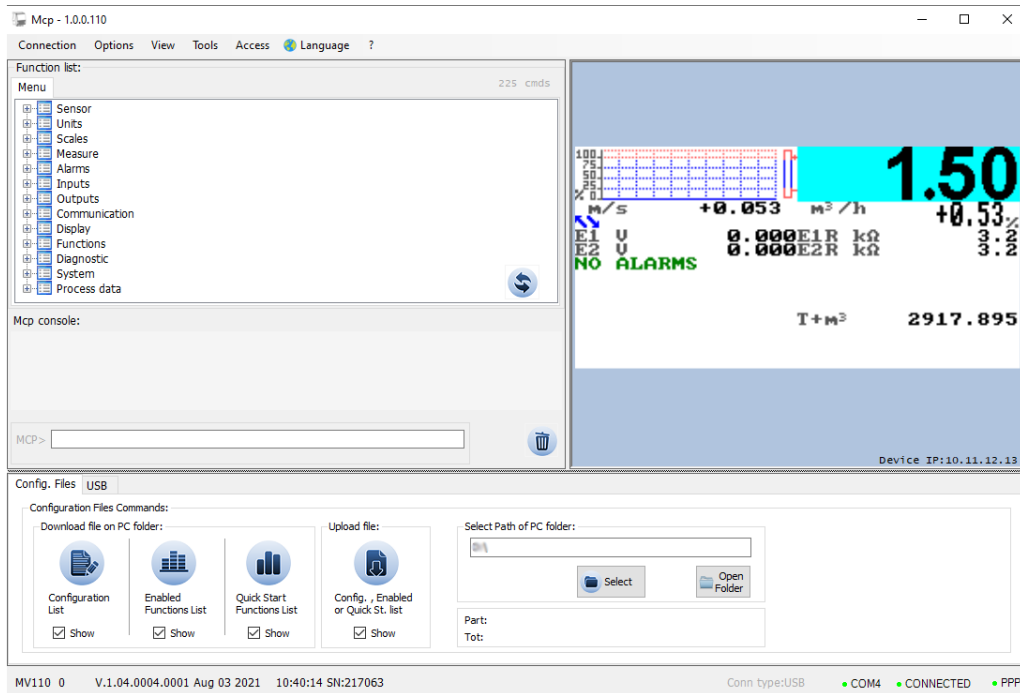

The manufacturer guarantees only English text available on our web site www.isoil.com

DATA LOGGER

Data is stored on micro SD card; the recorded data or the events, can be easily downloaded by the MCP INTERFACE, pressing the relevant key as shown below.

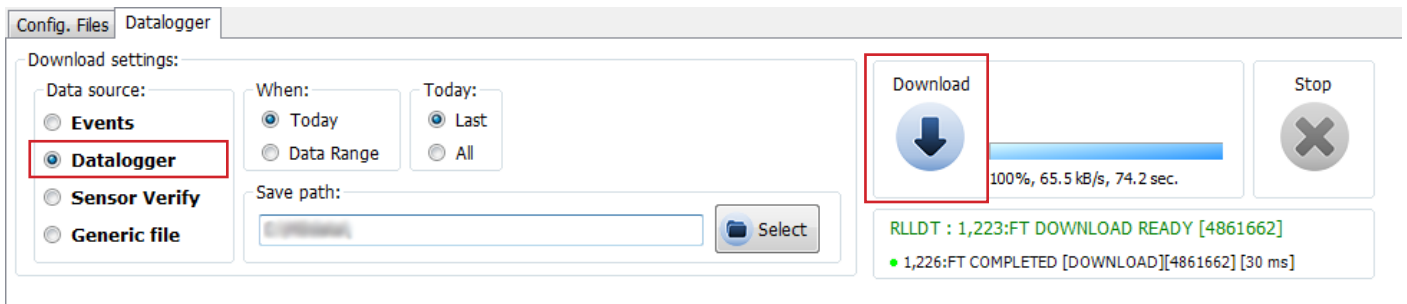

Note: to record correctly the data, the date and time shall be properly set.

Example of extrapolation of the data logger file:

N°Record.	View progressively the number of registered records.
Date.	The recording date viewing for each record.
Hours.	Time recording viewing for each record.
Total positive totalizer value.	Form Fields when the send flag is active on the totalizer T+.
Partial positive totalizer value.	Form Fields when the send flag is active on the totalizer P-.
Total negative totalizer value.	Form Fields when the send flag is active on the totalizer T-.
Partial negative totalizer value.	Form Fields when the send flag is active on the totalizer P-.
Total net totalizer value.	Form Fields when the send flag is active on the totalizer TN.
Partial net totalizer value.	Form Fields when the send flag is active on the totalizer PN.
Flow rate.	Form Fields present when the send flag is on the flow in units of measurement.
Flow rate %.	Form fields present when the flag of alarm recording is active (only N ° of present total alarms)
N ° active alarms.	Form fields present when the flag of alarm recording is active (only N ° of present total alarms)
Loss of current measured during insulation test.	Available value when recording the sensor test data is active.
Time rise A.	Available value when recording the sensor test data is active.
Time rise B.	Available value when recording the sensor test data is active.
Sensor test error code.	Available value when recording the sensor test data is active.

The manufacturer guarantees only English text available on our web site www.isoil.com

ACCURACY

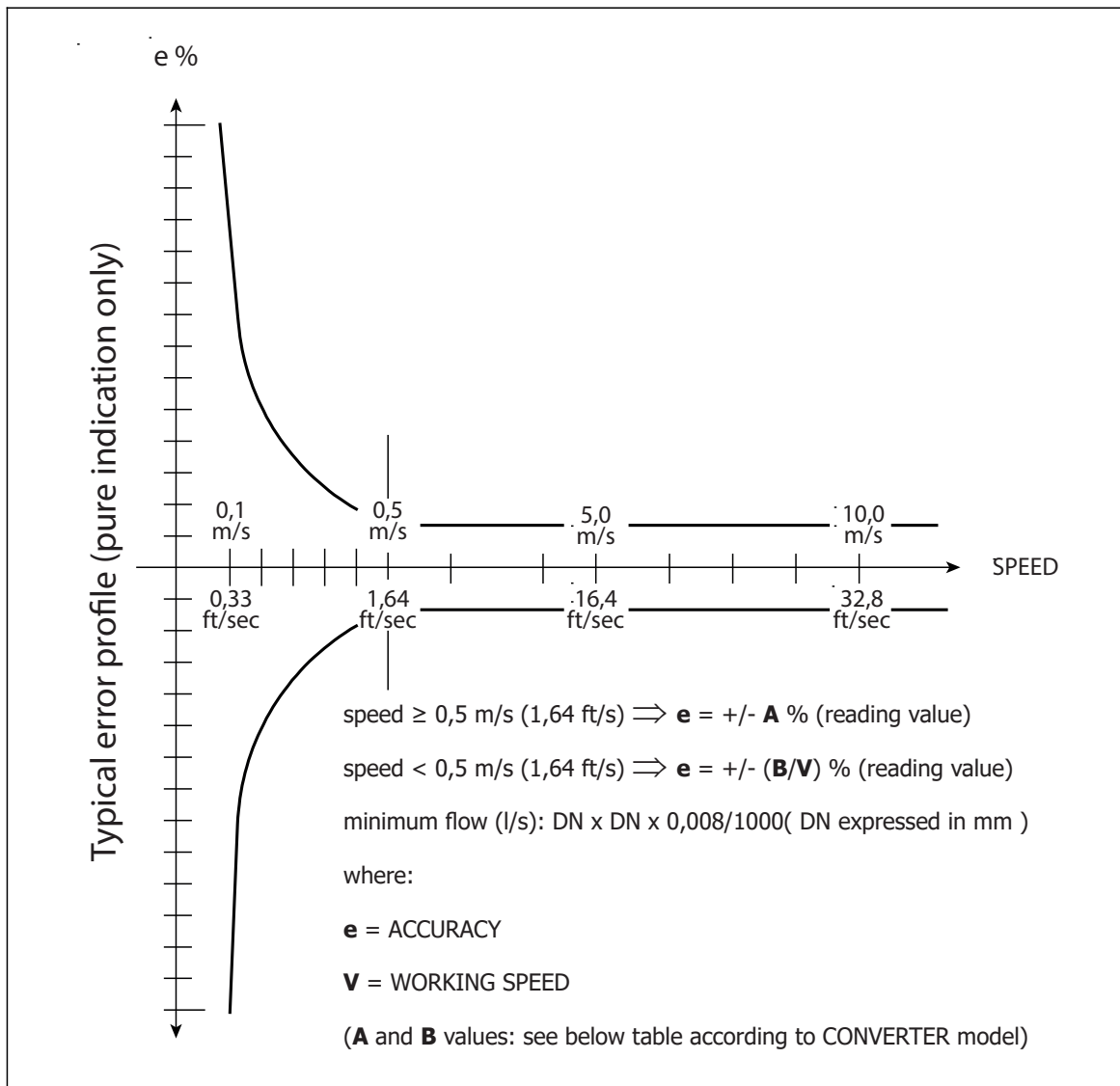

The manufacturer guarantees only English text available on our web site www.isoil.com

Fullbore Sensor

MS501/MS600/MS1000/MS2410/MS2500			MS5000		
A	B(m/s)	B(ft/s)	A	B(m/s)	B(ft/s)
0,4*	0,20	0,66	2	1	3,28

* = 0,25 (special velocity > 1 m/s)

Insertion sensor

See Sensor DATA SHEET.

Reference conditions below and as per internal testing procedures:

- Constant flow rate during the test
- Pressure: >30 Kpa
- Flow condition : fully developed flow profile
- Zero stability +/- 0,005 %

MI-001 OIML R49 CLASS1: MV145

The **MS2500** sensor's diameters listed below, coupled with **MV145**, are certified according to European Directive 2014/32/EU category MI-001 (OIML R49)

SIZE		Q3	Q2	Q1	R
mm	inch	m3/h			Q3/Q1
25	1	16	0,32	0,20	80
32	1 ¼	25	0,50	0,31	
40	1 ½	40	0,80	0,50	
50	2	63	1,3	0,79	
65	2 ½	100	2	1,25	
80	3	160	3,2	2	
100	4	250	5,0	3,13	
125	5	400	8,0	5,0	
150	6	630	13	7,88	
200	8	1000	20	12,50	
250	10	1600***	32	20	
300	12	2500**	50	31,25	
350	14	2500**	50	31,25	
400	16	4000**	80	50	
450	18	4000**	80	50	
500	20	6300	126	78,75	
600	24	10000	200	125	
700	28	10000	200	125	
800	32	16000*	320	200	
900	36	16000*	320	200	
1000	42	25000*	500	312,5	

SIZE		Q3	Q2	Q1	R
mm	inch	m3/h			Q3/Q1
25	1	16	0,26	0,16	100
32	1 ¼	25	0,40	0,25	
40	1 ½	40	0,64	0,40	
50	2	63	1,0	0,63	
65	2 ½	100	1,6	1,00	
80	3	160	2,6	1,60	
100	4	250	4,0	2,50	
125	5	400	6,4	4,00	
150	6	630	10	6,30	
200	8	1000	16	10,00	

(*) : Calibration flowrate 14000 m³/h - as for max rig flowrate L8

(**) : Calibration flowrate 1400 m³/h - as for max test rig flowrate L7

(***) Calibration flowrate 1100 m³/h - as for max test rig flowrate L6

The manufacturer guarantees only English text available on our web site www.isoil.com

MI-001 OIML R49 CLASS2: MV145

The **MS2500** sensor's diameters listed below, coupled with **MV145**, are certified according to European Directive 2014/32/EU category MI-001 (OIML R49)

SIZE		Q3	Q2	Q1	R
mm	inch	m³/h			Q3/Q1
25	1	16	0,16	0,10	160
32	1 ¼	25	0,25	0,16	
40	1 ½	40	0,40	0,25	
50	2	63	0,63	0,39	
65	2 ½	100	1,0	0,63	
80	3	160	1,6	1,0	
100	4	250	2,5	1,6	
125	5	400	4,0	2,5	
150	6	630	6,3	3,9	
200	8	1000	10	6,3	
250	10	1600***	16	10	
300	12	2500**	25	16	
350	14	2500**	25	16	
400	16	4000**	40	25	
450	18	4000**	40	25	
500	20	6300	63	39	
600	24	10000	100	63	
700	28	10000	100	63	
800	32	16000*	160	100	
900	36	16000*	160	100	
1000	42	25000*	250	156	

SIZE		Q3	Q2	Q1	R
mm	inch	m³/h			Q3/Q1
25	1	16	0,10	0,06	250
32	1 ¼	25	0,16	0,10	
40	1 ½	40	0,26	0,16	
50	2	63	0,40	0,25	
65	2 ½	100	0,64	0,40	
80	3	160	1,0	0,64	
100	4	250	1,6	1,0	
125	5	400	2,6	1,6	
150	6	630	4,0	2,5	
200	8	1000	6,4	4,0	
250	10	1600***	10	6,4	
300	12	2500**	16	10	
350	14	2500**	16	10	
400	16	4000**	26	16	
450	18	4000**	26	16	
500	20	6300	40	25	
600	24	10000	64	40	
700	28	10000	54	40	
800	32	16000*	102	64	
900	36	16000*	102	64	
1000	42	25000*	160	100	

(*) : Calibration flowrate 14000 m³/h - as for max rig flowrate L8

(**) : Calibration flowrate 1400 m³/h - as for max test rig flowrate L7

(***) Calibration flowrate 1100 m³/h - as for max test rig flowrate L6

SIZE		Q3	Q2	Q1	R
mm	inch	m ³ /h			Q3/Q1
25	1	16	0,06	0,04	400
32	1 ¼	25	0,10	0,063	
40	1 ½	40	0,16	0,10	
50	2	63	0,25	0,16	
65	2 ½	100	0,40	0,25	
80	3	160	0,64	0,40	
100	4	250	1,0	0,63	
125	5	400	1,6	1,0	
150	6	630	2,5	1,6	
200	8	1000	4,0	2,5	
250	10	1600***	6,4	4,0	
300	12	2500**	10	6,3	
350	14	2500**	10	6,3	
400	16	4000**	16	10	
450	18	4000**	16	10	
500	20	6300	25	16	
600	24	10000	40	25	
700	28	10000	40	25	
800	32	16000*	64	40	
900	36	16000*	64	40	
1000	42	25000*	100	63	

The manufacturer guarantees only English text available on our web site www.isoil.com

(*) : Calibration flowrate 14000 m³/h - as for max rig flowrate L8

(**) : Calibration flowrate 1400 m³/h - as for max test rig flowrate L7

(***) Calibration flowrate 1100 m³/h - as for max test rig flowrate L6

The manufacturer guarantees only English text available on our web site www.isoil.com

MPE - MI 001 - OIML R49 ACCURACY CLASS 1
(OIML R 49-1:2013 (E) - ISO4064-1:2017)

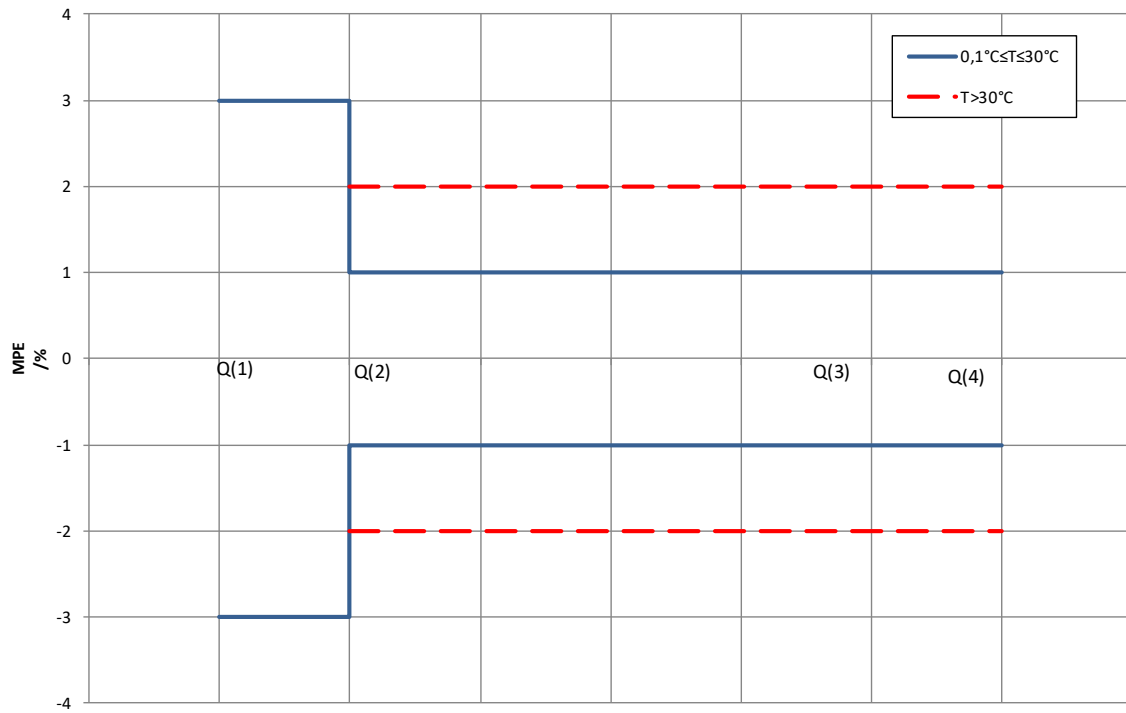

MPE - MI 001 - OIML R49 ACCURACY CLASS 2
(OIML R 49-1:2013 (E) - ISO4064-1:2017)

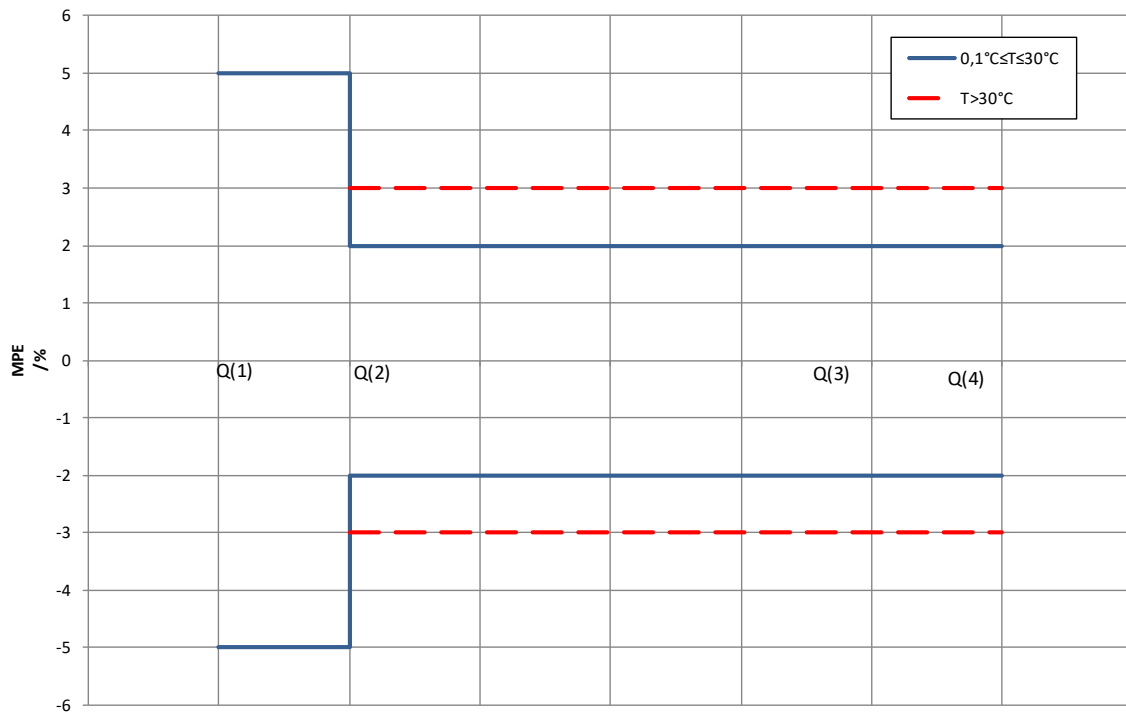

HOW TO ORDER

CODE\EXAMPLE		CODE\DESCRIPTION
Display		
B	A	Blind version (without display and programming keys, USB cable type A / USB Mini B is Required for programming)
	B	Graphic LCD WSTN - B/W-matrix points 128 x 64, 8 line/16 characters and 3 programming keys (mandatory for MI001)
Housing material		
0	0	Nylon PA6 with fiber glass, (IP67 only)
	1	Painted aluminium die casting
Version / Protection rate		
A	A	Compact version with sensor MS - IP67
	B	Separate version for wall monting, complete with Aluminium mounting accessories, (use C015/C016 cable max length 20 m) - IP67
	C	Compact version with display visible from the top -IP67
	D	Compact version - IP68 1,5 meters - ONLY aluminium housing
	E	Compact version with display visible from the top - IP68 1,5 meters - ONLY aluminium housing
	F	Separate version with sensor MS - IP68 1,5 meters - ONLY aluminium housing
Main Power supply		
0	0	Without Main Power Supply
	1	Power supply : 100 ... 240 VAC- 45/66 Hz
	2	Power supply : 12...48 VDC
Batteries		
A	A	2 Lithium thionyl chloride batteries (n° 1 on slot 1 - n° 1 on slot 2)
	B	4 Lithium thionyl chloride batteries (n° 2 on slot 1 - n° 2 on slot 2)
	C	6 Lithium thionyl chloride batteries (n° 3 on slot 1 - n° 3 on slot 2)
	D	6 Alkaline or NiMh batteries SIZE D (on slot 3)
	E	Board set for Lithium (slot 1-2) (Batteries NOT Supplied)
	F	Board set for Alkaline (slot 3) (Batteries NOT Supplied)
Analog Input/Output		
A	0	Without Analog Input/Output
	1	N° 1 Input for n° 1 pressure sensor (pressure sensor to be ordered separately)
	2	N° 2 Inputs for n° 2 pressure sensors (pressure sensors to be ordered separately)
	3	N° 1 Input for n° 1 PT 100/500/1000 THERMAL PROBE (probe to be ordered separately)
	4	N° 2 Inputs for n° 2 PT 100/500/1000 THERMAL PROBE (probes to be ordered separately)
	5	N° 1 Analog Output (4/20 mA) - Active or Passive (by wiring) if the Main Power is SELECTED ; ONLY PASSIVE if powered by BATTERIES
	6	Option 1 + 5
	7	Option 2 + 5
	8	Option 3 + 5
	9	Option 4 + 5
a	Option 1 + 3	
Digital Input/Output		
0	A	Without Digital Input/Output
	B	N° 2 ON/OFF output (max 50 Hz - max 100 mA) + N° 1 ON/OFF input
	C	N° 4 ON/OFF output (max 50 Hz - max 100 mA) + N° 3 ON/OFF input
	D	N° 4 ON/OFF output (max 50 Hz - max 100 mA) + N° 3 ON/OFF input + Potted Cable

Communication Gateway		
0	0	Without Gateway
	1	RS485 NOT insulated - Modbus
	2	Others
Data Logger		
A	A	MicroSD Memory 4 GB : Data Logger + RTC (Real Time Clock)
	B	MicroSD Memory 4 GB : Data Logger + RTC (Real Time Clock) + BIV (Built In Verificator)
	C	MicroSD Memory 4 GB : Data Logger + RTC (Real Time Clock) + Meter Data (Real Time Converter & Sensor Data on SD Memory)
	D	MicroSD Memory 4 GB : Data Logger + RTC (Real Time Clock) + BIV + Meter Data
Special Features		
0	0	None
	1	WITH ANTICONDENSE CAP
Connectors for POWER SUPPLY and CABLES FROM SENSOR (Separate Version) (Maximum 5 connectors including IN/OUT connectors)		
A	A	NO CONNECTORS
	B	POWER SUPPLY (n° 1 connector)
	C	SEPARATE VERSION (n° 2 connectors)
	D	POWER SUPPLY (n° 1 connector)+ SEPARATE VERSION (n° 2 connectors)
Connectors for INPUTS/OUTPUTS (Maximum 5 connectors including connectors for Power Supply and cables from sensor) (other combinations on request)		
0	0	NO CONNECTORS
	1	n.1 Pressure or n.1 Temperature (n.1 connector)
	2	n.2 Pressure or n.2 Temperature (n. 2 connector)
	3	n.2 Digital Outputs - n.1 Digital Input (n.1 connector)
	4	n.2 Digital Outputs - n.1 Digital Input + RS485 (n.1 connector)
	5	n.2 Digital Outputs - n.1 Digital Input (n.1 connector) + n.1 Pressure or n.1 Temperature (n.1 connector)
	6	n.2 Digital Outputs + n.1 Output 4-20 mA (n.1 connector)
	7	n.2 Digital Outputs (n.1 connector) n.1 Output 4-20 mA + RS485 (n.1 connector) (NOT ALLOWED OPTIONS "CONNETECTOR ON INPUTS/OUTPUTS")
	8	n. 1 Modbus over RS485 (n.1 connector) (NOT ALLOWED OPTIONS "CONNETECTOR ON INPUTS/ OUTPUTS")
	9	n. 1 Modbus over RS485 (n.1 connector) +n.1 Pressure or n.1 Temperature (n.1 connector)
	a	N° 4 ON/OFF output (max 50 Hz - max 100 mA) - n° 1 x 6 Poles Connector
	b	N° 4 ON/OFF output (max 50 Hz - max 100 mA) n° 1 x 6 Poles Connector + N° 3 ON/OFF input, n° 1 x 4 Poles Connector
MID APPROVAL		
A	A	NONE
	B	MI-001/OIMLR49-CLASS 1
	C	MI-001/OIMLR49-CLASS 2

The manufacturer guarantees only English text available on our web site www.isoil.com

Complete code
example for
order

→ **MV145-B0A0A0A0A0A0A**

ISOIL INDUSTRIA S.p.A.

HEAD OFFICE	SERVICE
Via Fratelli Gracchi, 27 20092 Cinisello Balsamo (MI) Tel +39 02 66027.1 Fax +39 02 6123202 sales@isoil.it	isomagservice@isoil.it

If you want to find the complete list of our distributors access at the following link:

<http://www.isoil.it/en>



Due to the constant technical development and improvement of its products, the manufacturer reserves the right to make changes and/or modify the information contained in this document without notice.